

2009 International Energy Conservation Code

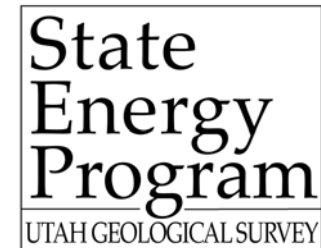

Complex HVAC

Guide Sponsors



Presented by Ken Baker – K energy

Presentation developed by
University of Idaho Integrated Design Lab and
K energy



503.2.5.1 Demand Control Ventilation

Topic	2006 IECC	2009 IECC
Demand control ventilation	None	Requires demand control ventilation for spaces larger than 500ft ² with an average occupant load of 40 people per 1000ft ² .



503.2.5.1 Demand Control Ventilation

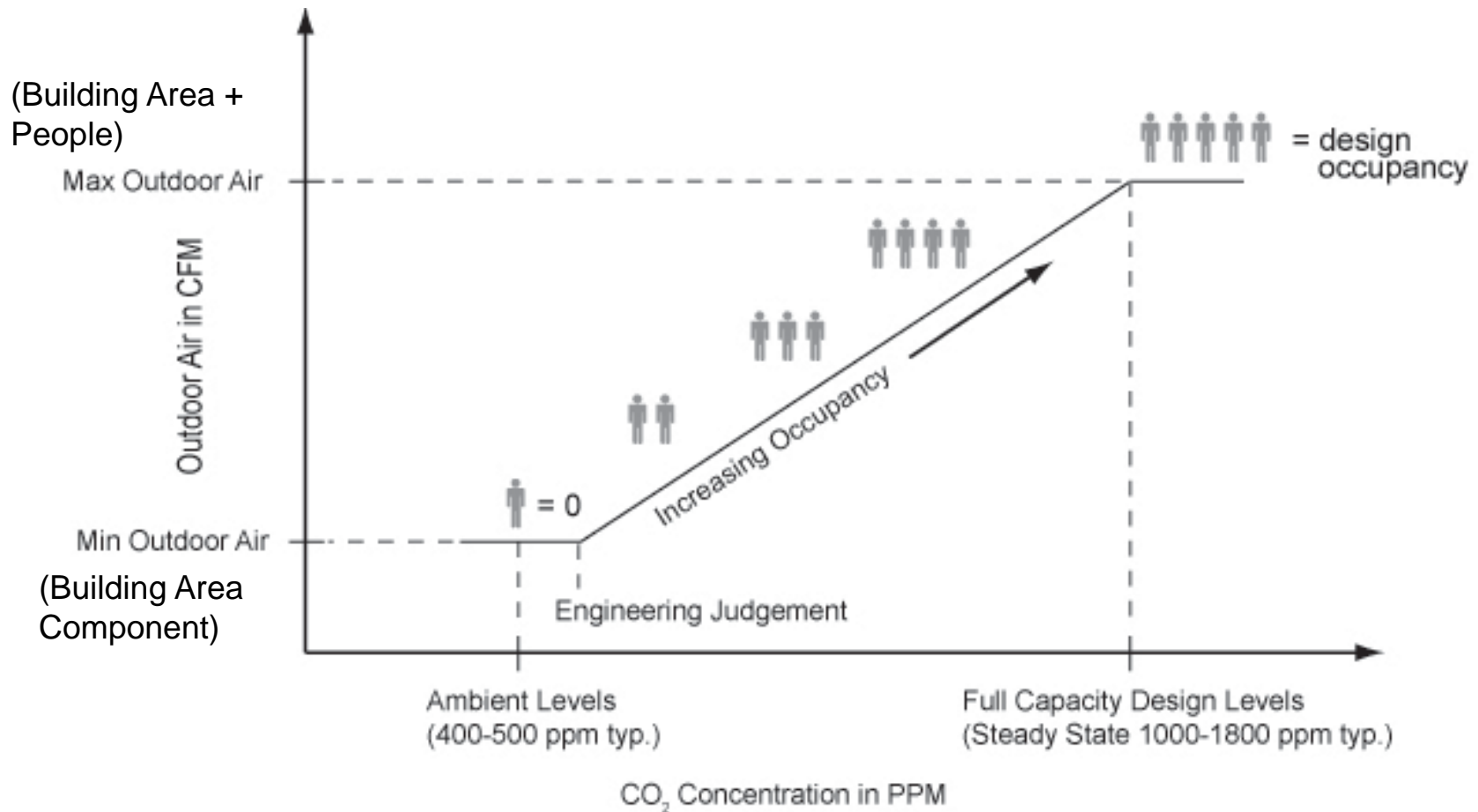

503.2.5.1 Demand Control Ventilation

Single Zone System

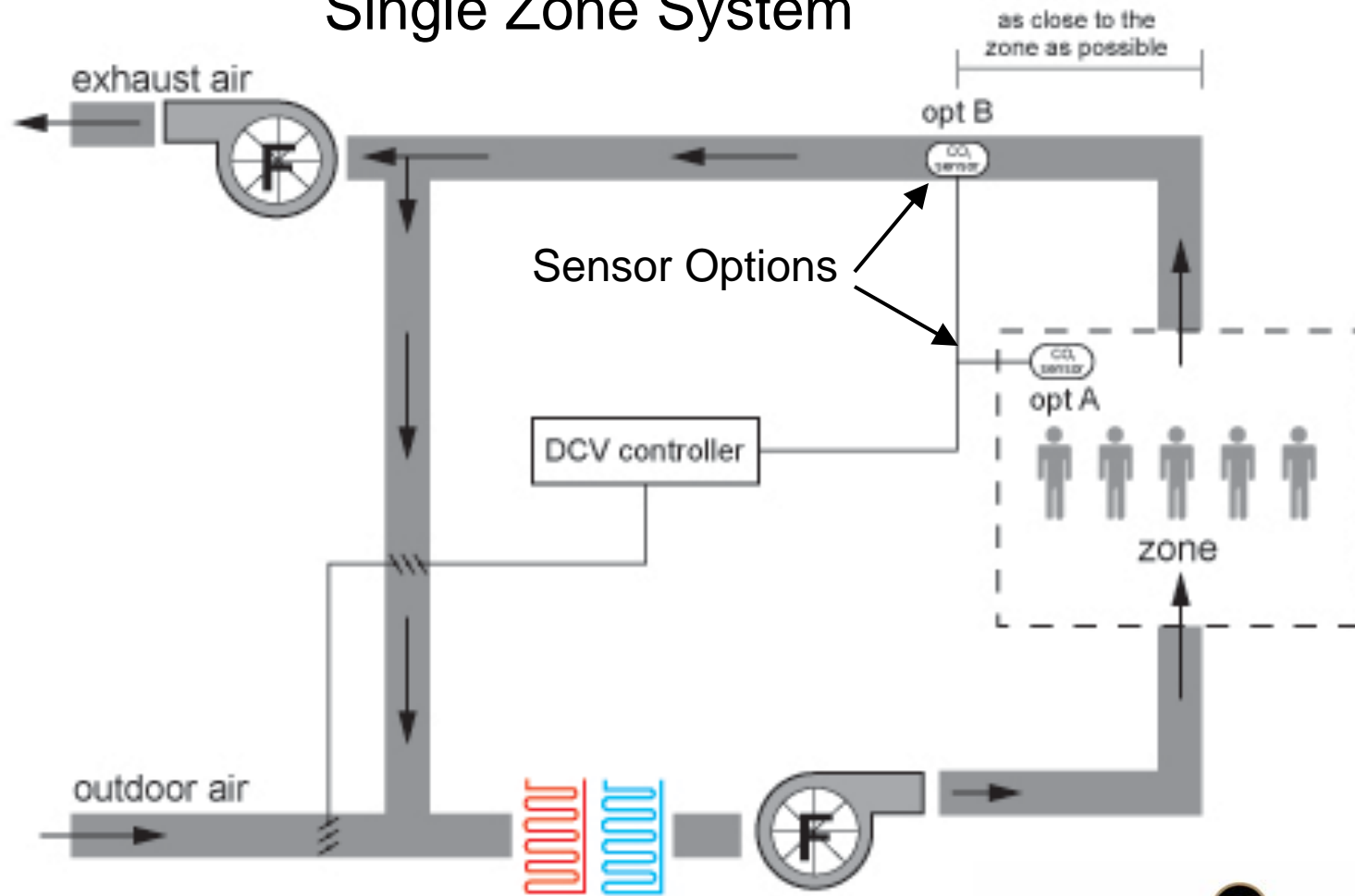

Images Created By:

INTEGRATED



503.2.5.1 Demand Control Ventilation

Multi Zone (complex system) Poor Sensor Placement

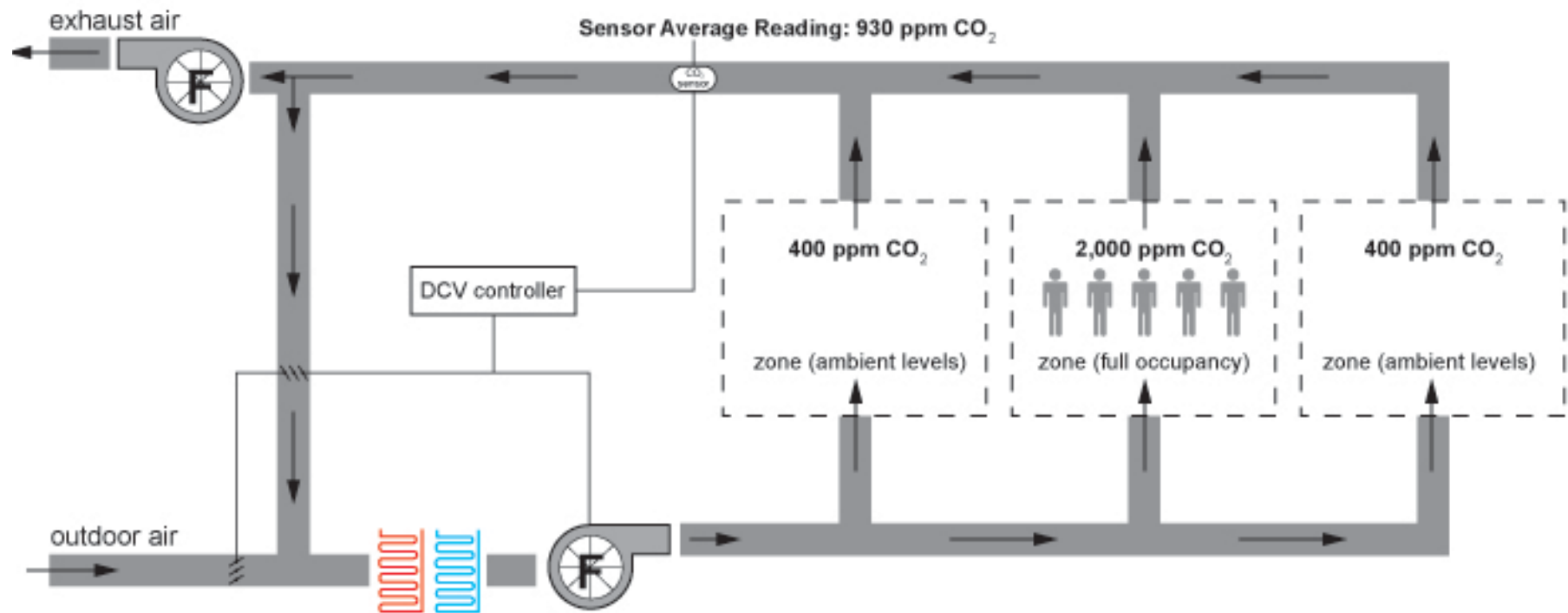

503.2.5.1 Demand Control Ventilation

Multi Zone (complex system) Proper Sensor Placement

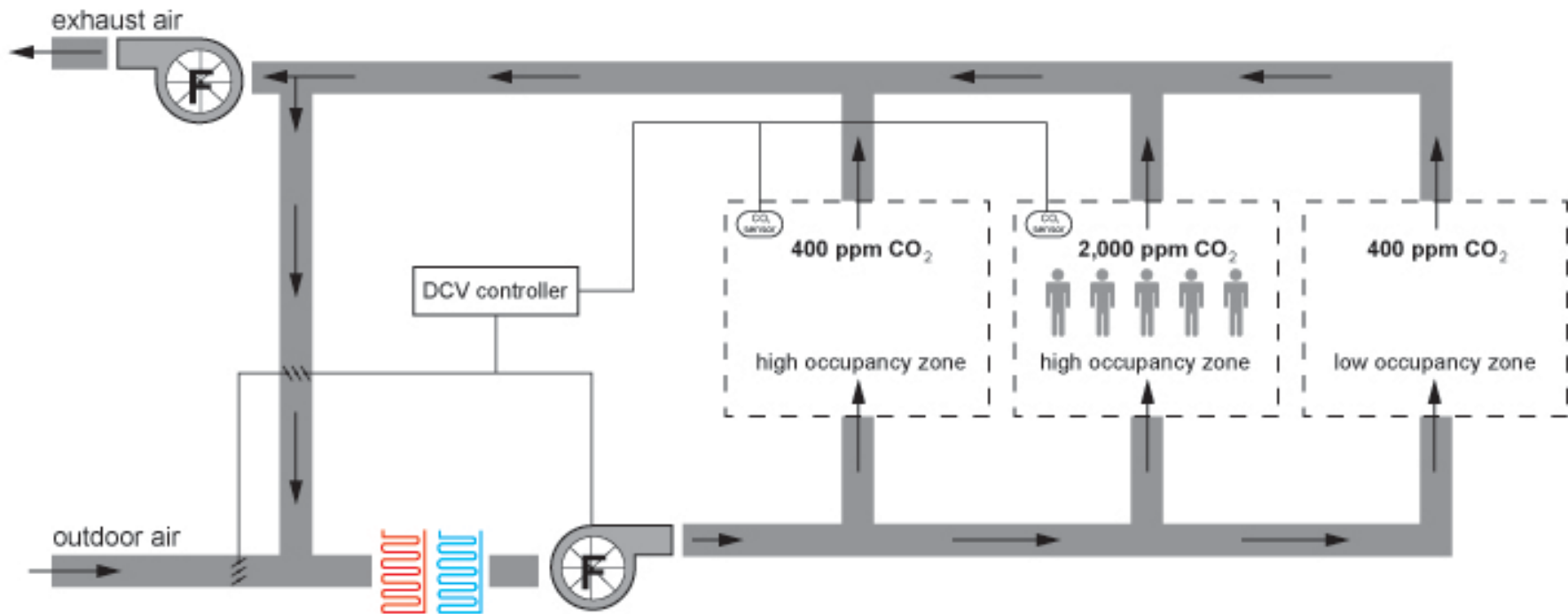

503.3 Simple HVAC Systems and Equipment

Unitary or packaged, single zone controlled by a single thermostat in the zone served. Includes:

Simple Systems

- ✓ Unitary packaged cooling system
 - ✓ Split system cooling
 - ✓ Packaged terminal A/C
 - ✓ Heat pump cooling
 - ✓ Unitary packaged heating
 - ✓ Split system heating
 - ✓ Packaged terminal heat pump
 - ✓ Fuel-fired furnace
 - ✓ Electrical resistance heating
 - ✓ Two-pipe heating systems w/o cooling
 - ✓ Economizers
-
-

503.3.1 Economizers

Table 503.3.1(1)

CLIMATE ZONES	ECONOMIZER REQUIREMENT
1A, 1B, 2A, 7, 8	No requirement
2B, 3A, 3B, 3C, 4A, 4B, 4C, 5A, 5B, 5C, 6A, 6B	Economizers on cooling systems $\geq 54,000$ Btu/h ^a

^a The total capacity of all systems without economizers shall not exceed 480,000 Btu/h per building, or 20 percent of its air economizer capacity, whichever is greater

503.3.1 Economizers

Minimum Outside Air- DX Cooling On

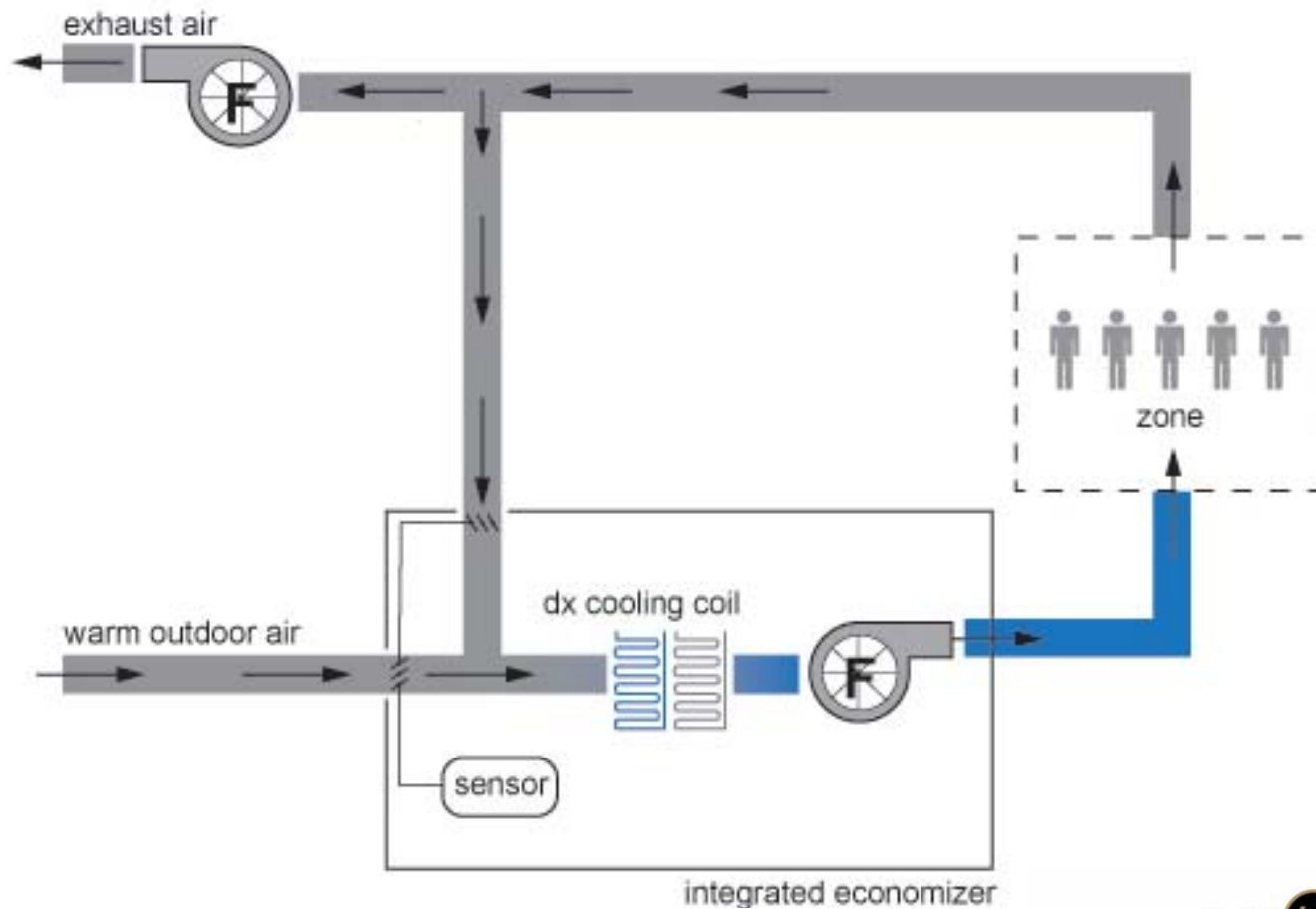

Images Created By:

INTEGRATED



503.3.1 Economizers

Full Outside Air- DX Cooling OFF

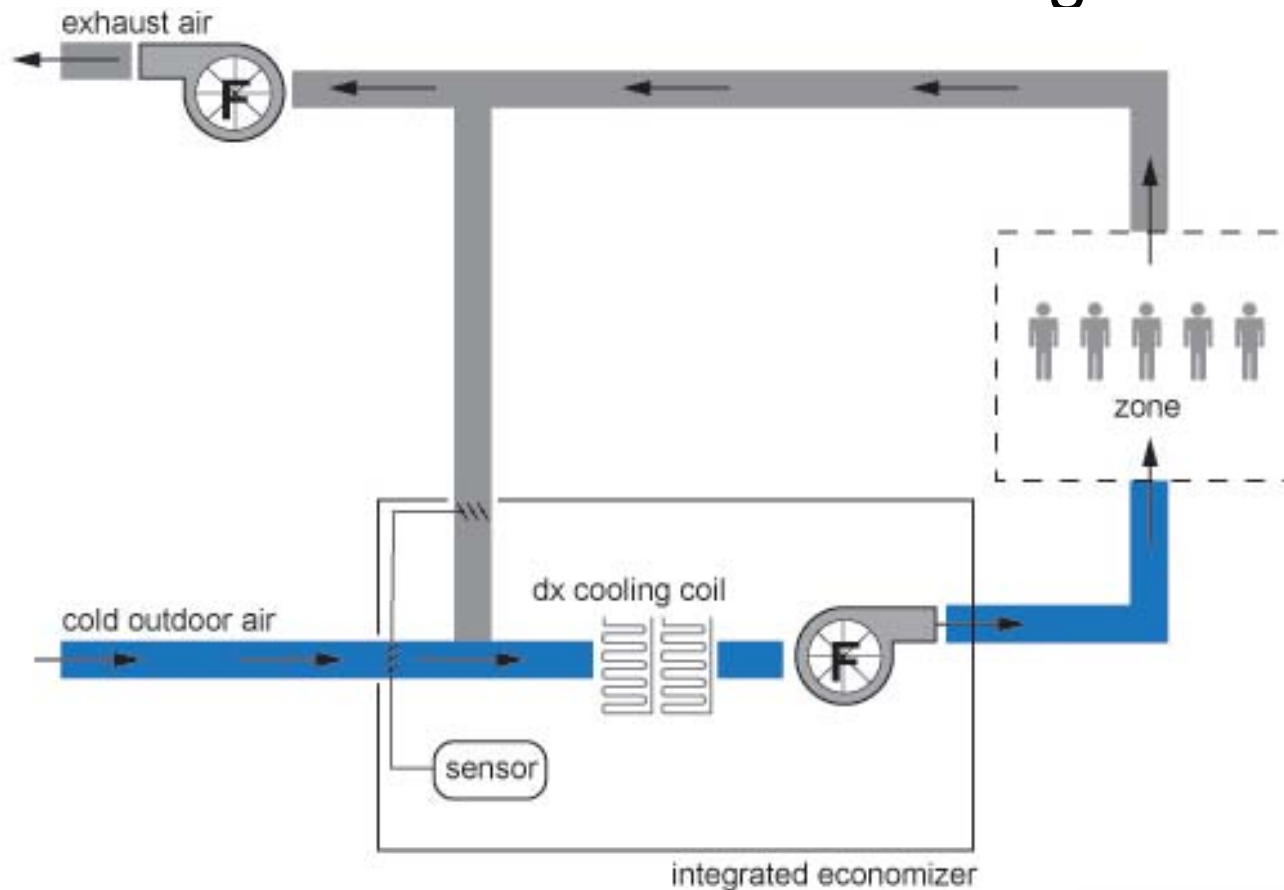

503.3.1 Economizers

Floating Outside Air- DX Cooling Final Stage

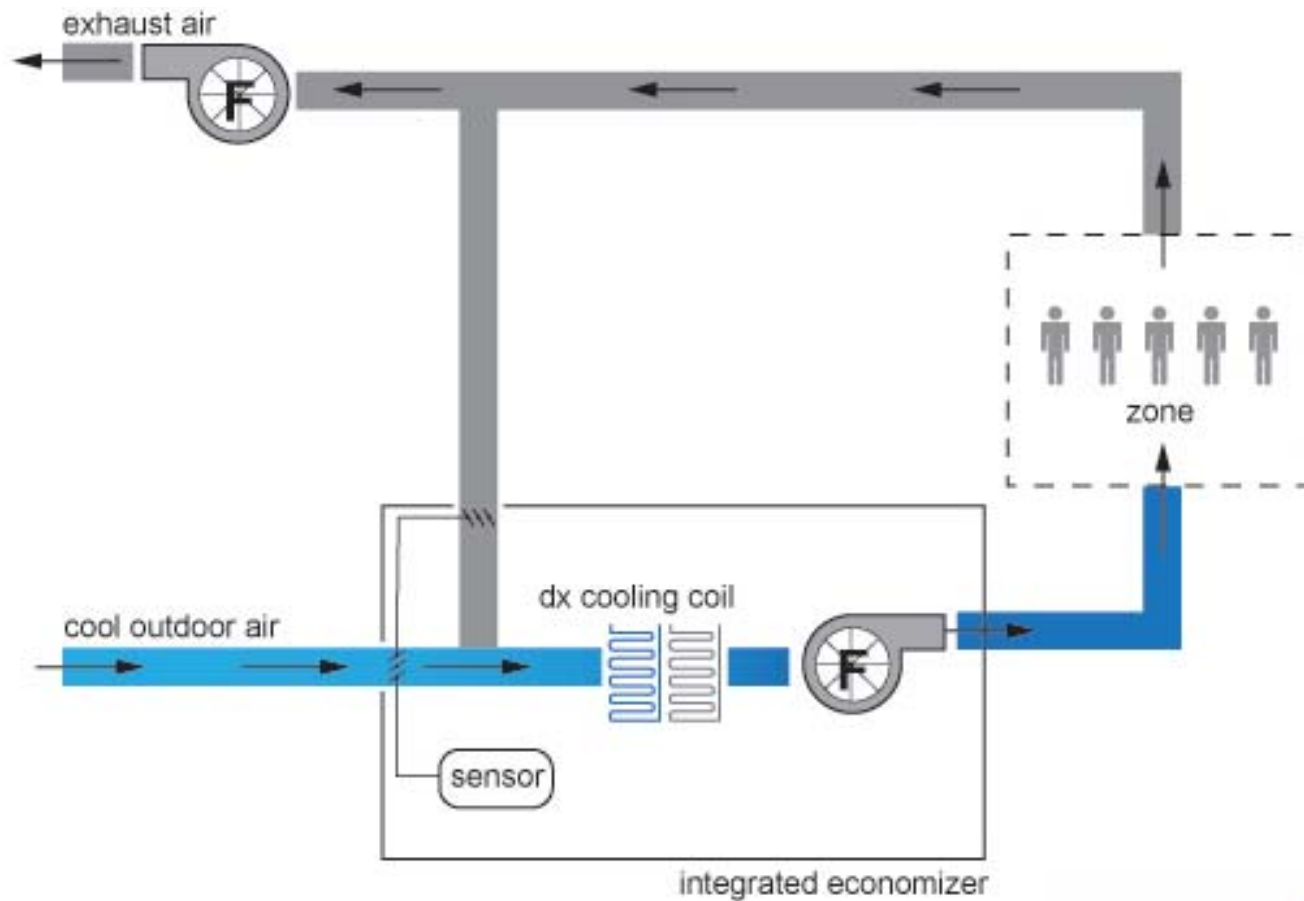

503.3.1 Economizers

Air side economizer are required

- ✓ In climate zones shown in 503.3.1(1).
 - ✓ Must meet minimum efficiency requirements of tables 503.2.3(1) and 503.2.3(2).
 - ✓ Must be able to provide 100% of design supply air as outside air.
 - ✓ Must be an integrated economizer.
 - ✓ Air relief systems must be provide to avoid building overpressurizing during economizer use.
-
-

503.3.1 Economizers

Air side economizer and equipment performance
exceptions

- ✓ Where cooling equipment is covered by the minimum efficiency in table 503.2.3(1) or 503.2.3(2) and meets or exceeding the minimum EER by the percentages show in 503.3.1(2).
 - ✓ Units less than 54,000 Btu/hr (4.5 tons)
 - ✓ Spaces that require filtration equipment to meet minimum ventilation requirements
 - ✓ System with air or evaporatively cooled condensers which serve spaces with open case refrigeration.
-
-

503.3.1 Economizers

Trade-off high cooling efficiency for economizer

Table 503.3.1(2)

CLIMATE ZONES	COOLING EQUIPMENT PERFORMANCE IMPROVEMENT (EER OR IPLV)
2B	10% Efficiency Improvement
3B	15% Efficiency Improvement
4B	20% Efficiency Improvement

503.4 Complex HVAC Systems and Equipment

This section applies to all HVAC equipment and systems not included in Section 503.3

Complex Systems

- ✓ Packaged VAV reheat
 - ✓ Built-up VAV reheat
 - ✓ Built-up single-fan, dual-duct VAV
 - ✓ Built-up or packaged dual-fan, dual-duct VAV
 - ✓ Four-pipe fan coil system with central plant
 - ✓ Hydronic heat pump with central plant
 - ✓ Any other multiple-zone system
 - ✓ Hydronic space heating system
 - ✓ Economizers
-
-

503.4 Complex HVAC Systems and Equipment

503.4.1 Air and water side economizer requirements and equipment

503.4.2 VAV Fan Control

503.4.3 Hydronic Systems and Controls

503.4.4- Heat Rejection Equipment Fan Speed Control

503.4.5 VAV Systems

503.4.6 Heat Recovery for Service Hot Water Heating

503.4.7 Hot Gas Bypass Limitation



503.4.1 Economizers

Section 503.4.1 covers all equipment not covered in 503.3.1 (mainly water side economizers).

Air and water side economizer requirements

- ✓ In climate zones shown in 503.3.1(1).
- ✓ Must be capable to operate at 100% outside air even if additional mechanical cooling is required (integrated economizer).



503.4.1 Economizers

exceptions

- ✓ Water side economizer that are capable of cooling 100% of the expected load at outside air temperature of 50 F dry bulb/45 F wet bulb and below.
 - ✓ Where cooling equipment is covered by the minimum efficiency in table 503.2.3(1), 503.2.3(2) or 503.2.3(6) and meets or exceeding the minimum EER by the percentages show in 503.3.1(2).
 - ✓ Where cooling equipment is covered by the minimum efficiency in table 503.2.3(7) and meets or exceeding the minimum Integrated Part Load Value (IPLV) by the percentages show in 503.3.1(2).
-
-

503.4 Complex HVAC Systems and Equipment

Background: Heat Rejection Equipment

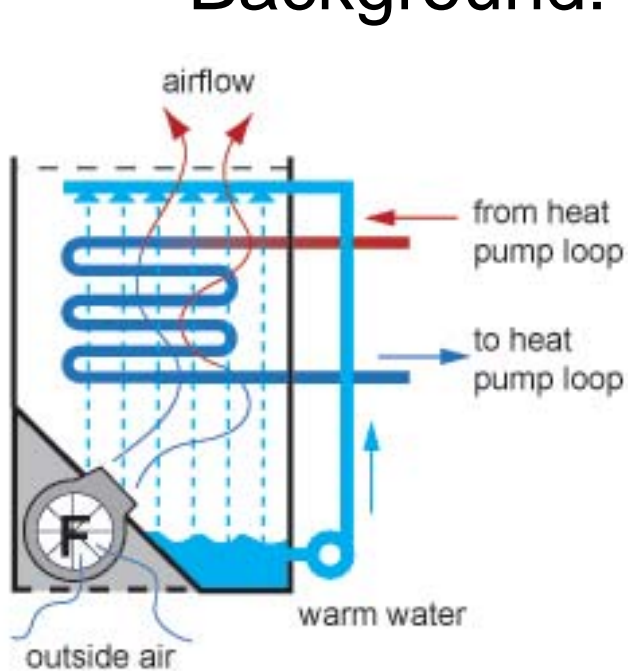

Closed loop/circuit cooling tower

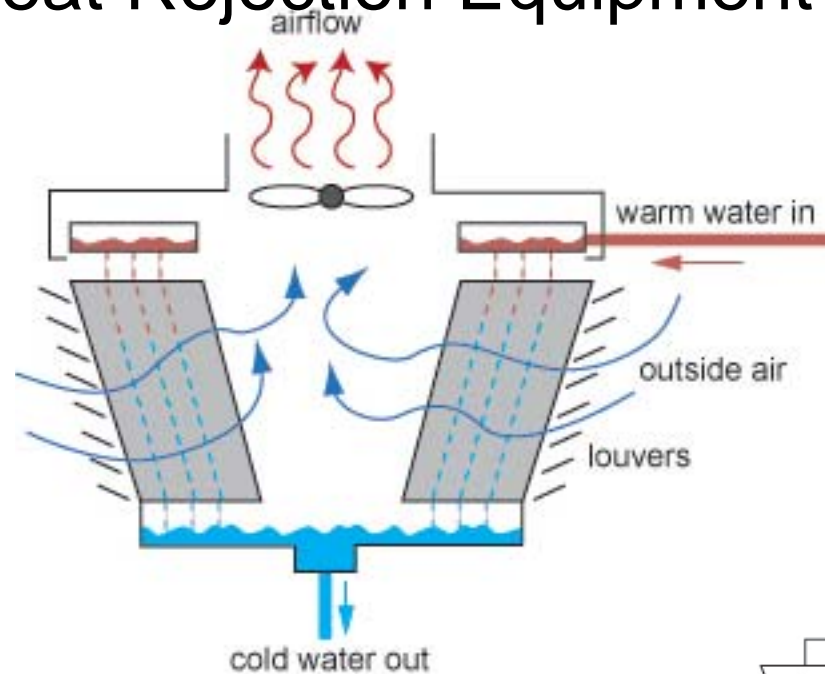

Open loop/circuit cooling tower

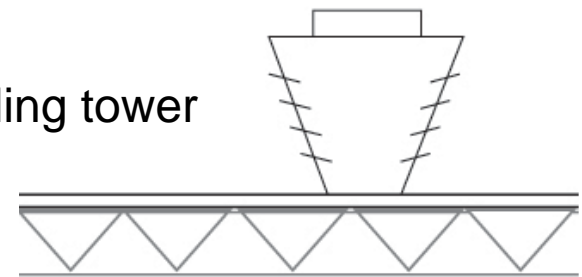

503.4 Complex HVAC Systems and Equipment

Background: Chillers

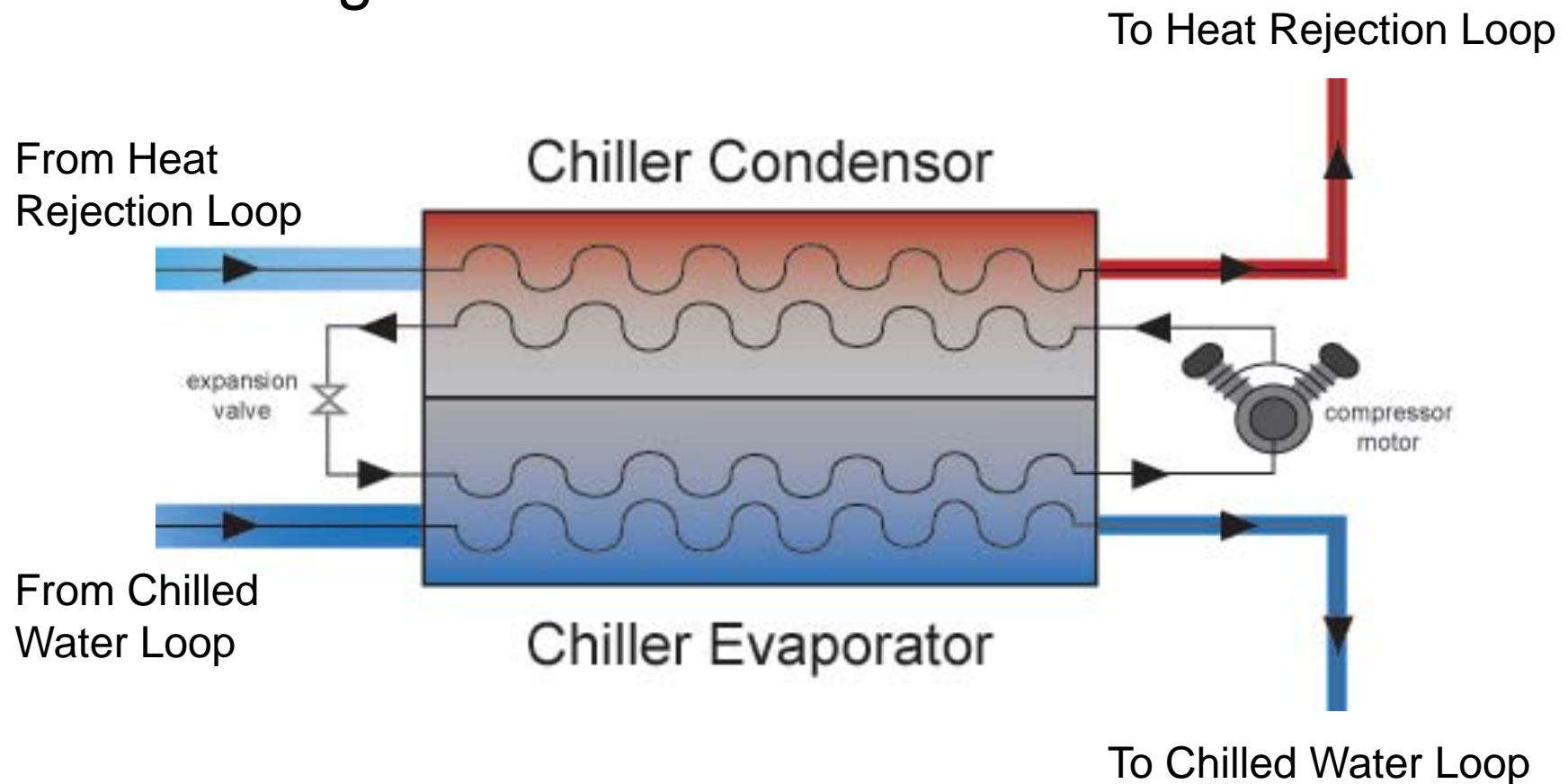

503.4.1 Economizers- Water Side

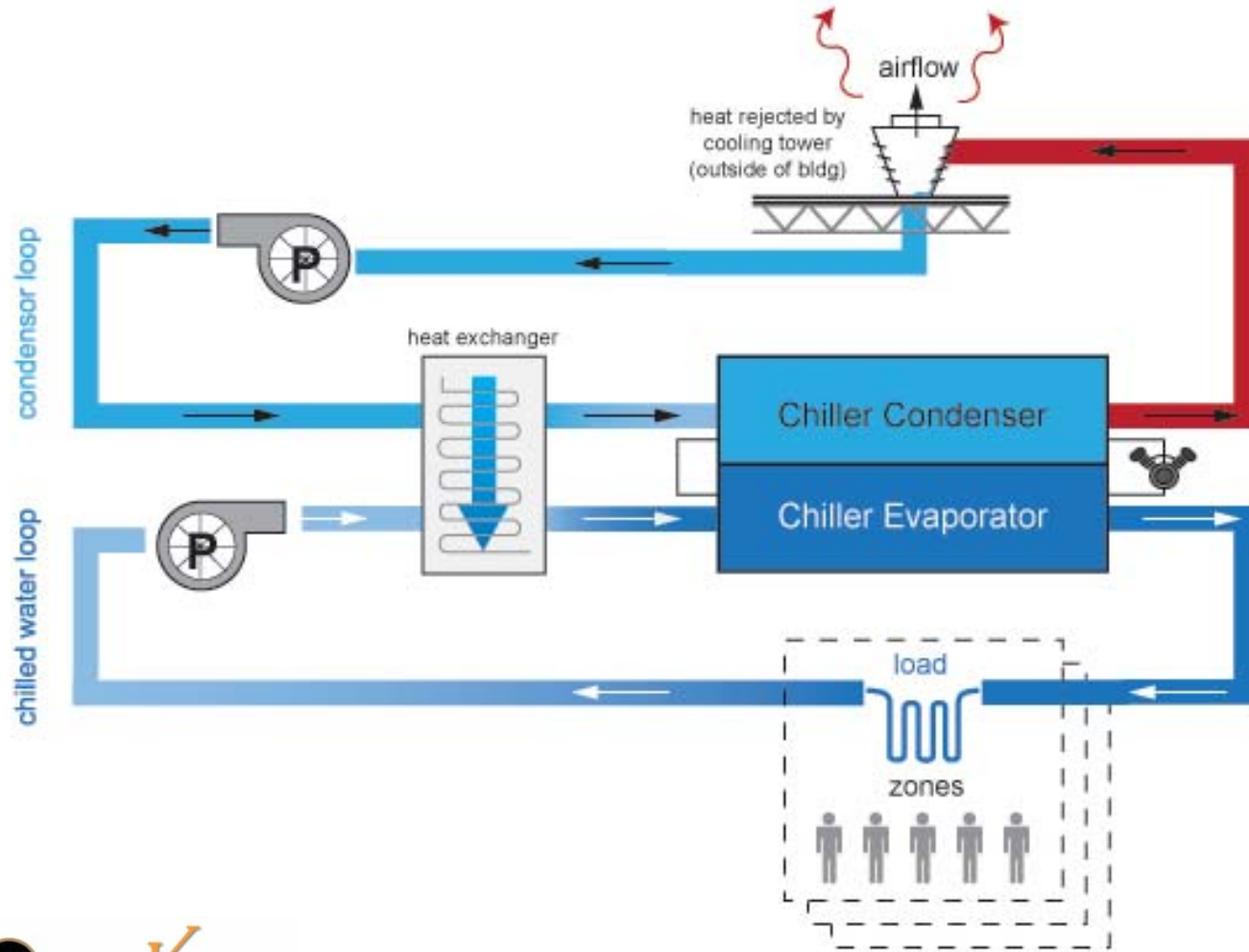

503.4.1 Economizers-Water Side Air Precooling

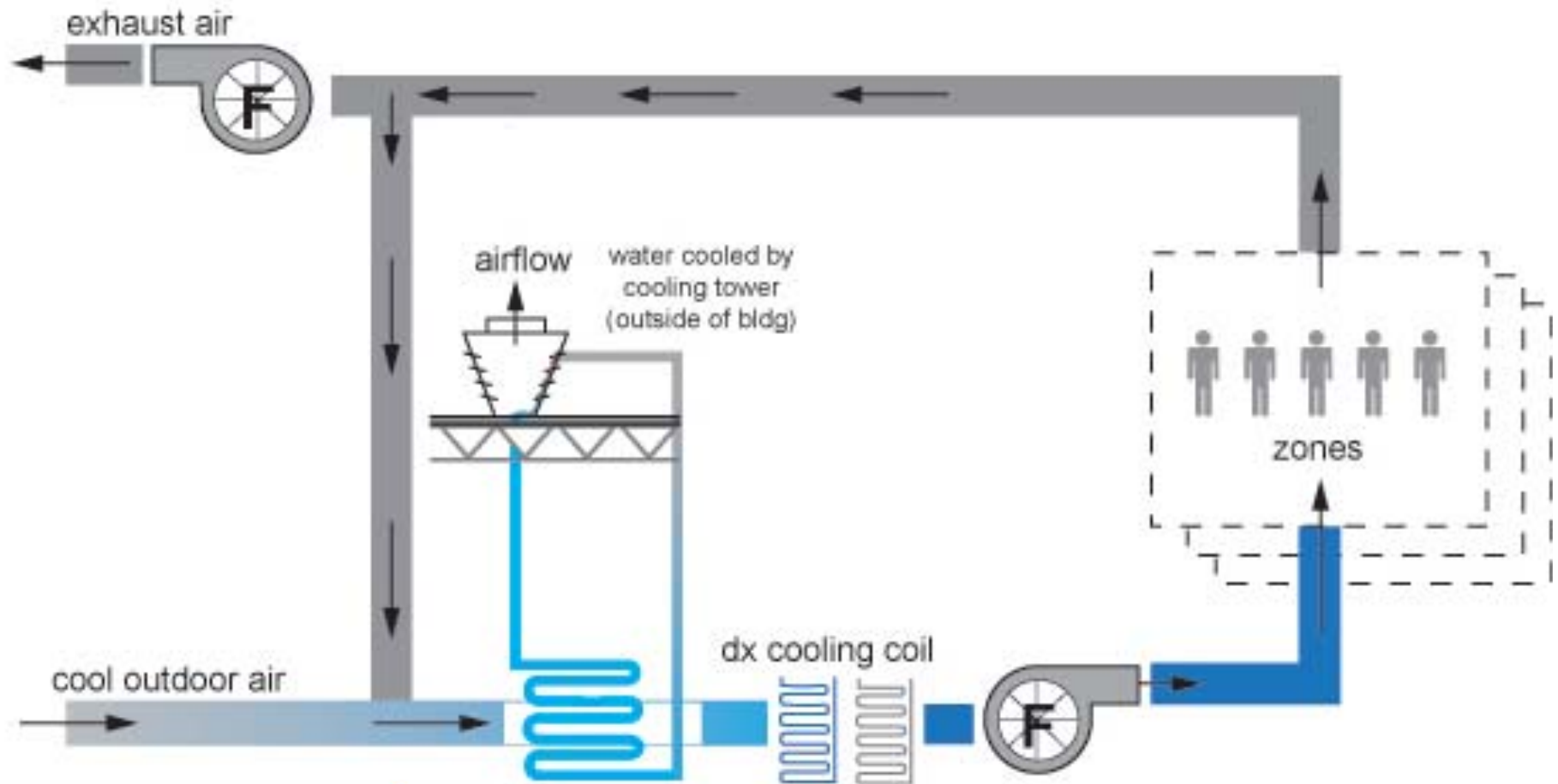

503.4.1 Economizers- Air Side

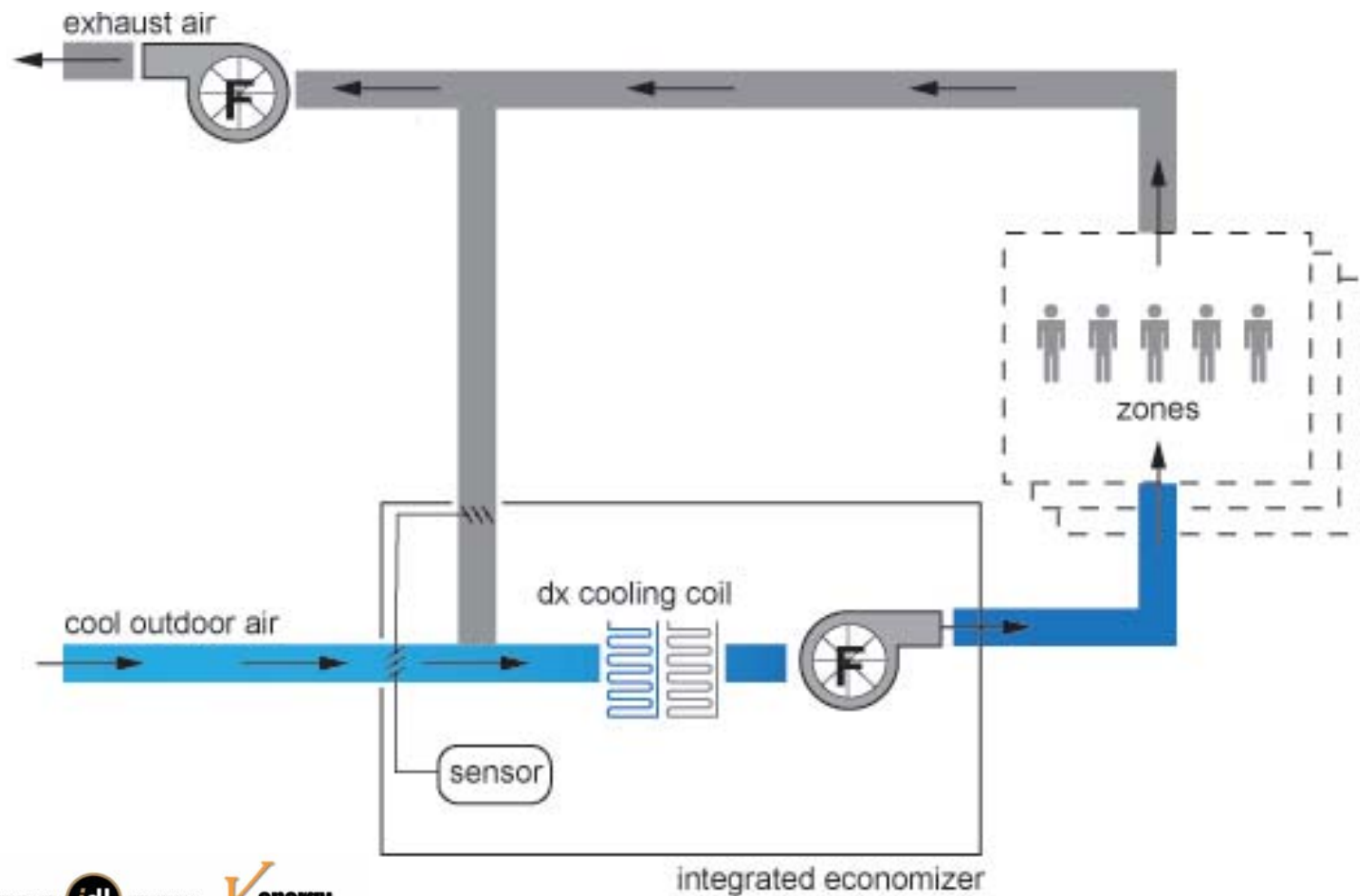

503.4.2 VAV Fan Control

Individual fans with motors $\geq 10\text{hp}$

- ✓ Must be driven by a mechanical or electrical variable speed drive

OR

- ✓ Have controls or devices to result in fan motor demand $\leq 30\%$ of their design wattage at 50% of design airflow when static pressure set point = $1/3$ of the total design static pressure



503.4.3 Hydronic System Controls



Limit reheat/re-cool of fluids
503.4.3.1 through 503.4.3.3

Multiple-packaged boiler
systems designed to deliver
conditioned water/steam
into common distribution
system

- ✓ Automatic controls
capable of sequencing
operation of the
boilers
-
-

503.4.3 Hydronic System Controls



Limit reheat/re-cool of fluids
503.4.3.1 through 503.4.3.3

Single boilers > 500,000 Btu/h input design capacity
require -

- ✓ Multi-staged or modulating burner required

503.4.3 Hydronic Systems

3-Pipe System- 503.4.3.1

- ✓ Can't use a common return, prohibited by code
- ✓ This system is not allowed.

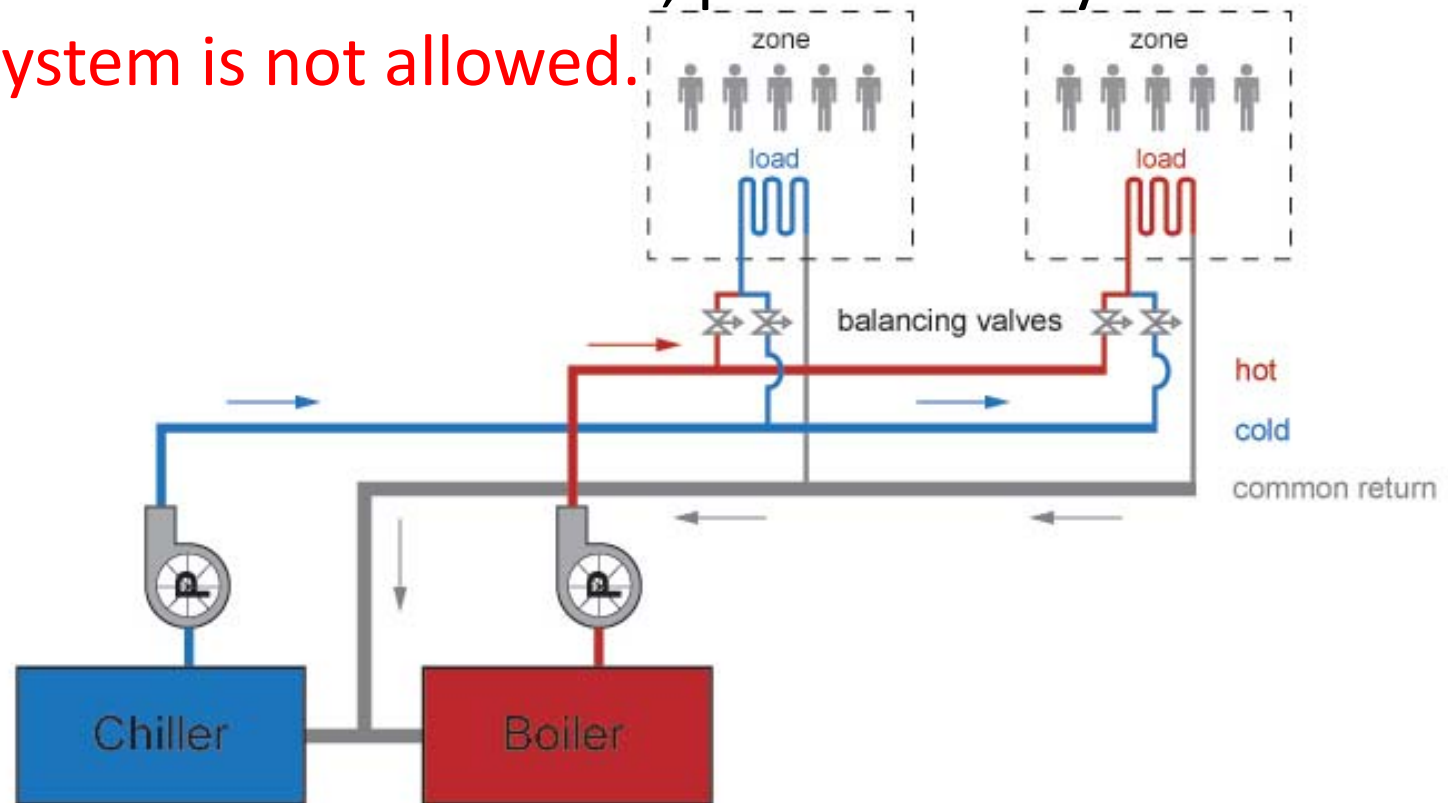

503.4.3 Hydronic Systems

2-Pipe Changeover System – 503.4.3.2

Heating Mode

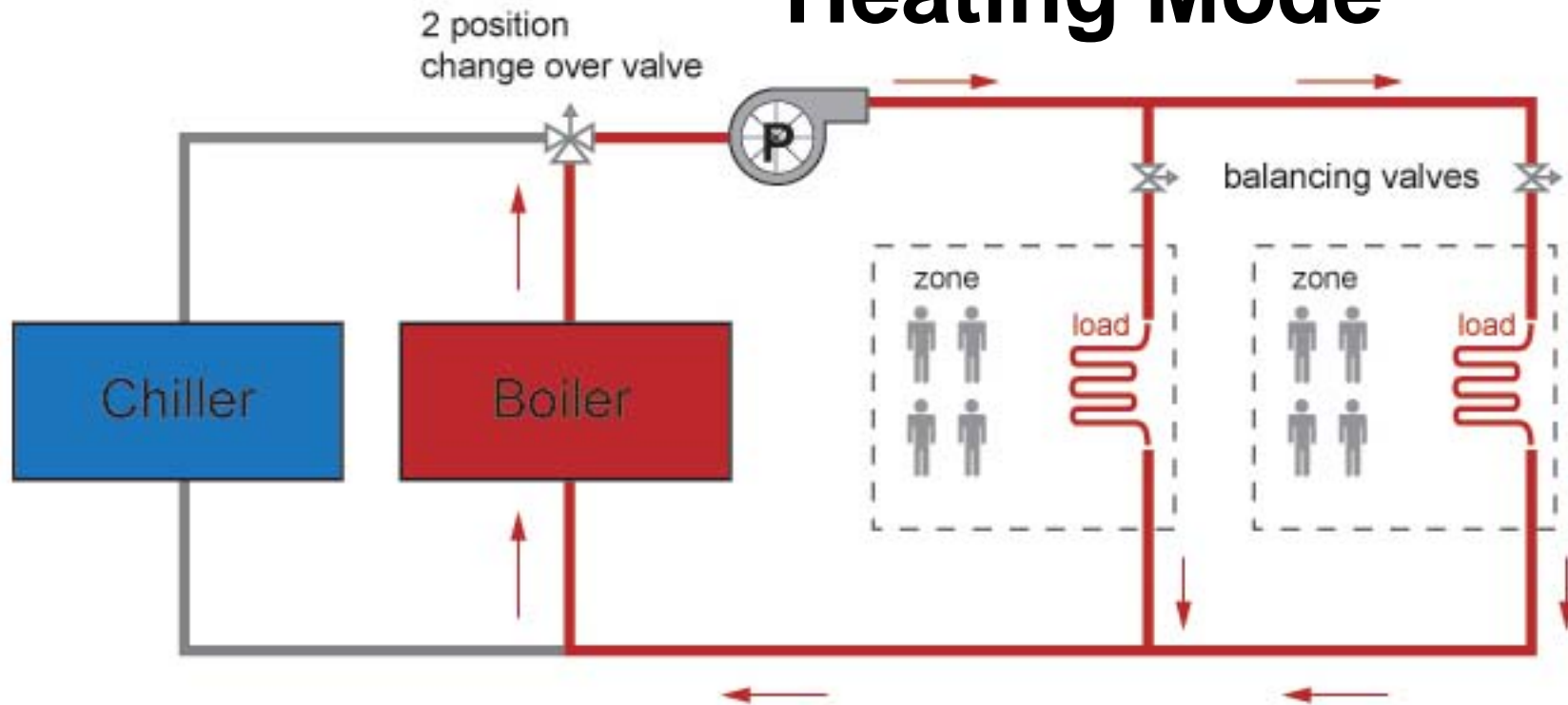

503.4.3 Hydronic Systems

2-Pipe Changeover System – 503.4.3.2

Cooling Mode

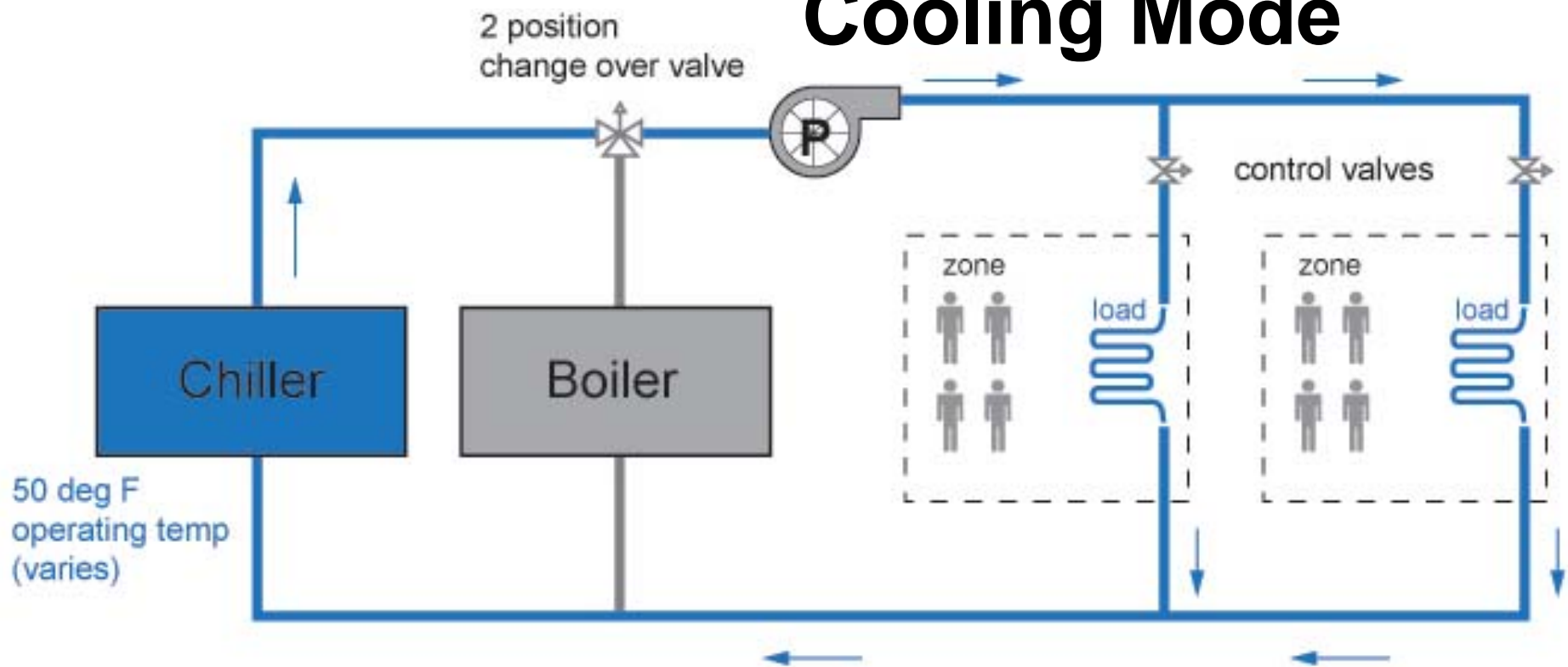

503.4.3 Hydronic Systems

2-Pipe Changeover System – 503.4.3.2

503.4.3:“The heating of fluids that have been previously mechanically cooled and the cooling of fluids that have been previously mechanically heated shall be limited in accordance with Sections 503.4.3.1 through 503.4.3.3.”

Requirements

- ✓ Dead band between changeover > 15°F outside temperature
 - ✓ Operation in one mode for at least 4 hours before change over
 - ✓ No more than 30°F between heating and cooling fluid temperatures at changeover
-
-

503.4.3 Hydronic Systems

2-Pipe Changeover System – 503.4.3.2

System Ready to Changeover Heating to Cooling

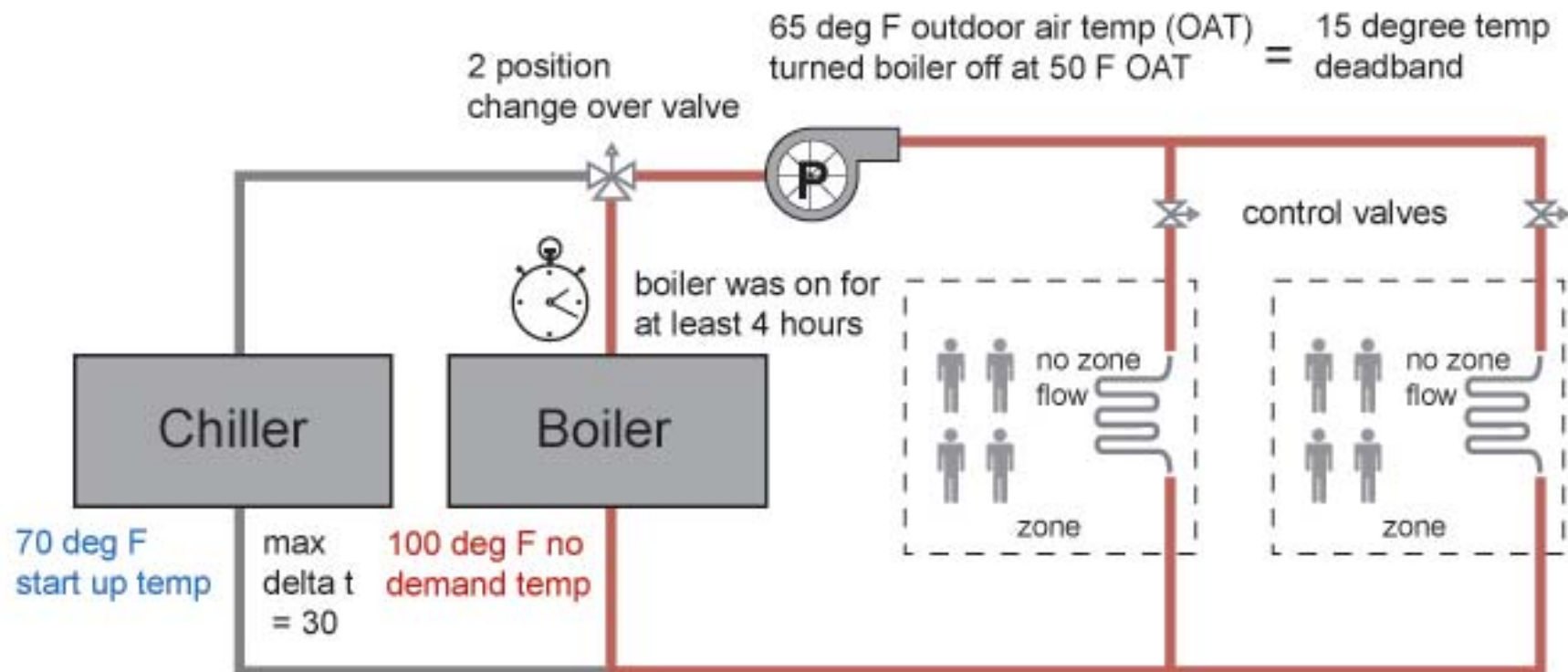

503.4.3.3 Hydronic Water Loop Heat Pump Systems

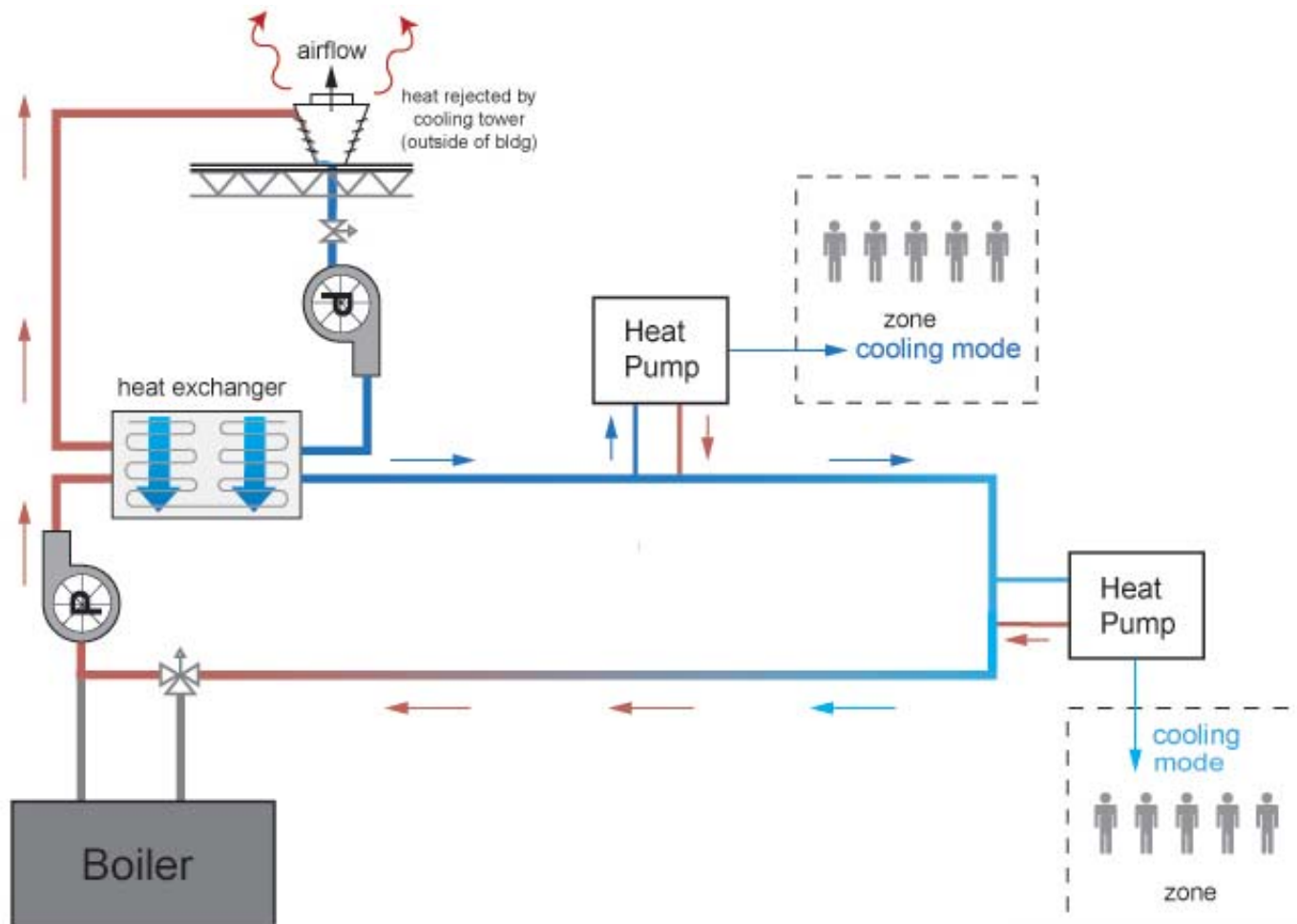

503.4.3.3 Hydronic Water Loop Heat Pump Systems

Some cooling, some heating
Boiler and Cooling Tower- **OFF**

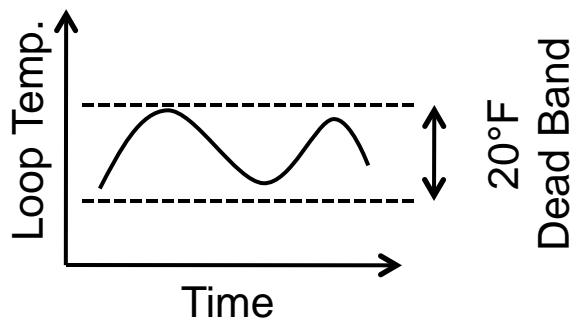

Most Zones in Cooling
Cooling Tower - **ON**

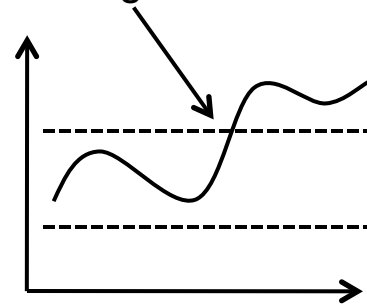

Most Zones in Heating
Boiler - **ON**

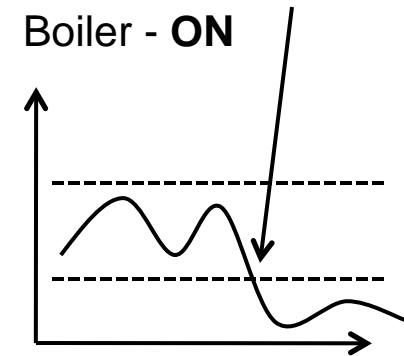

Temperature dead band of at least 20°F (503.4.3.3.1)

Exception: where system loop temp optimization controller is installed and can determine the most efficient operating temp based on real time conditions of demand and capacity

503.4.3.3 Hydronic Water Loop Heat Pump Systems (cont'd)

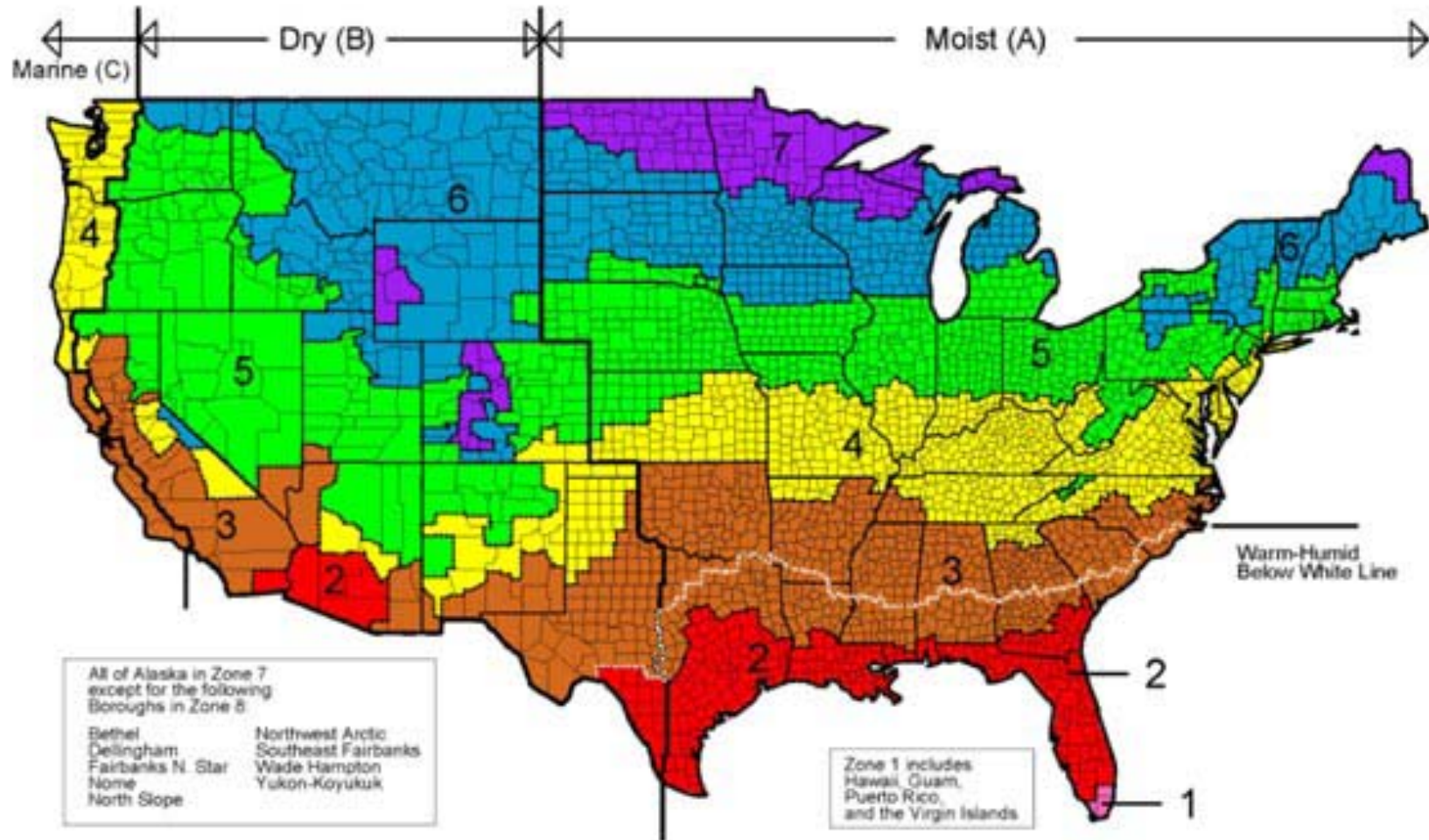

503.4.3.3 Hydronic Water Loop Heat Pump Systems (cont'd)

Heat rejection equipment required in Climate Zones 3 and 4 (503.4.3.3.2) ✓

Closed-circuit cooling tower used directly in heat pump loop
- Install either automatic valve to bypass all but a minimal flow of water around tower OR lower leakage positive closure dampers to be provided

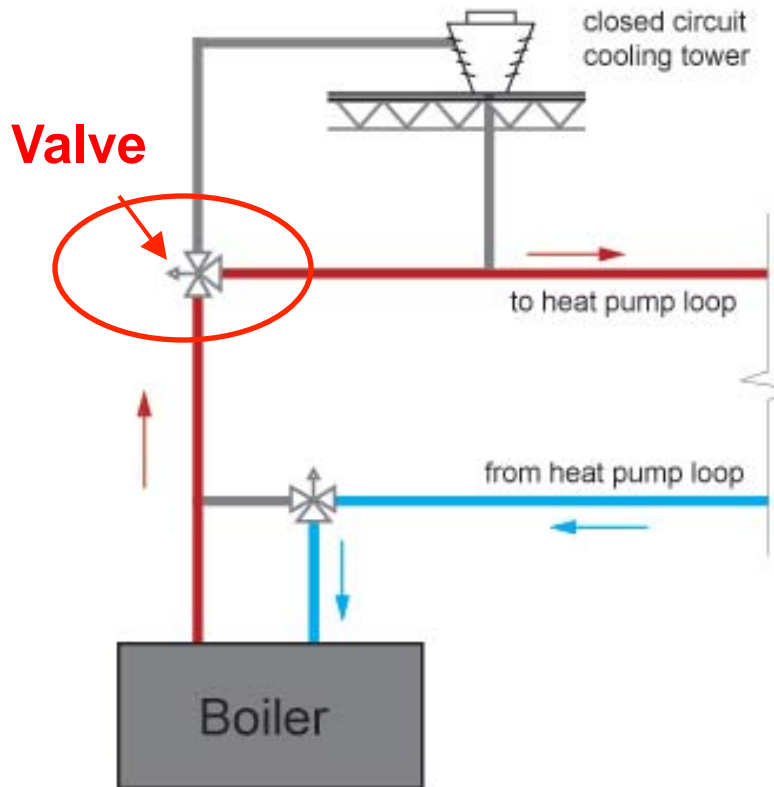

OR

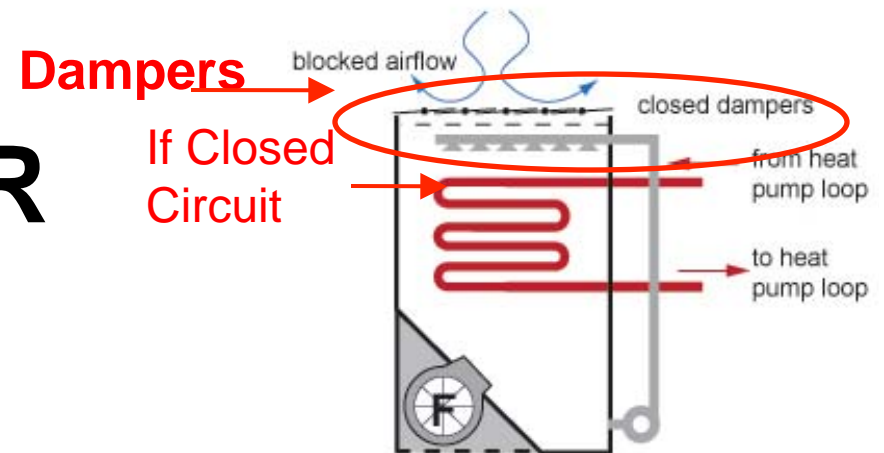

503.4.3.3 Hydronic Water Loop Heat Pump Systems (cont'd)

Heat rejection equipment required in Climate Zones 3 and 4 (503.4.3.3.2)

Open-circuit tower used directly in heat pump loop

✓ Install automatic valve to bypass all heat pump water flow around tower

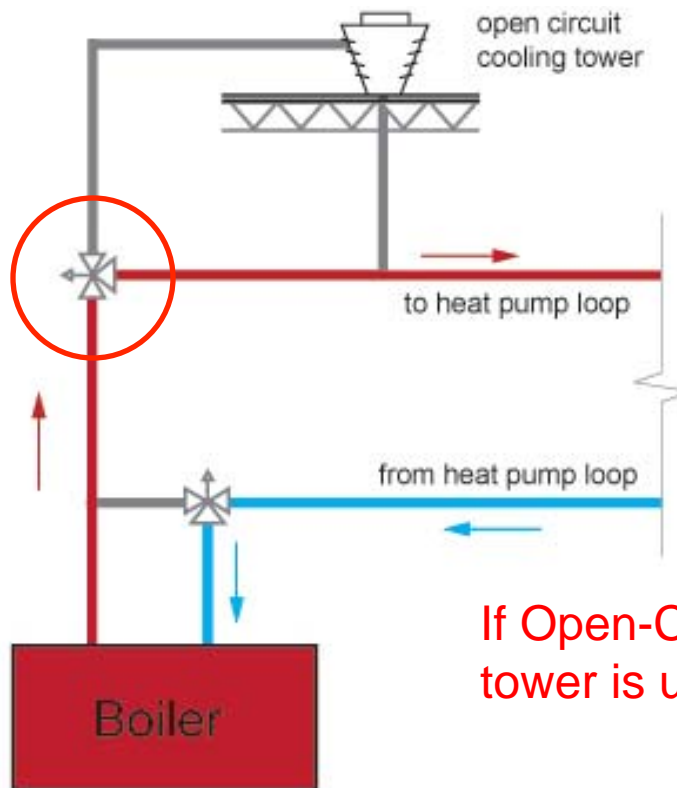

If Open-Circuit tower is used

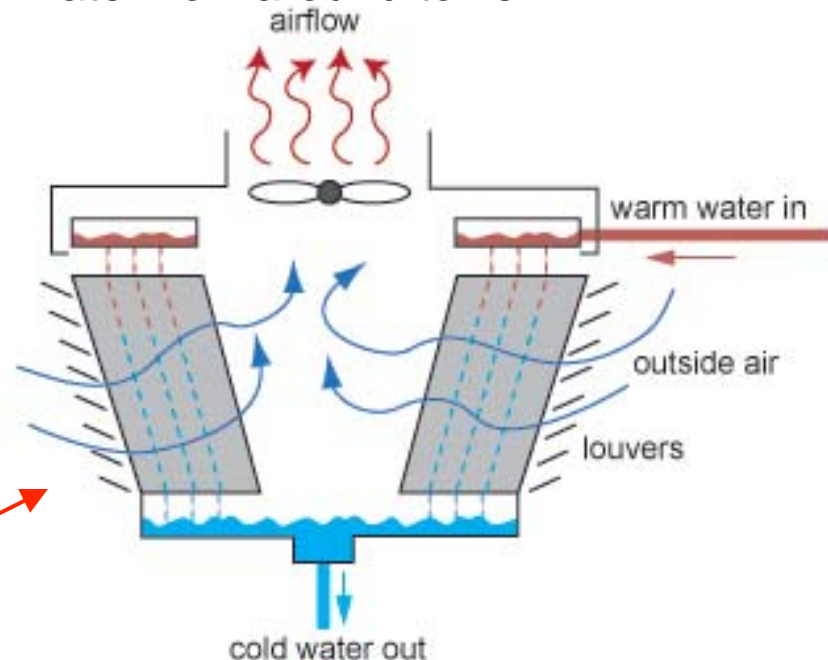

503.4.3.3 Hydronic Water Loop Heat Pump Systems (cont'd)

Heat rejection equipment required in Climate Zones 3 and 4 (503.4.3.3.2)

- ✓ Open- or closed-circuit used in conjunction with separate heat exchanger to isolate cooling tower from heat pump loop
 - Heat loss controlled by shutting down the circulation pump on cooling tower loop

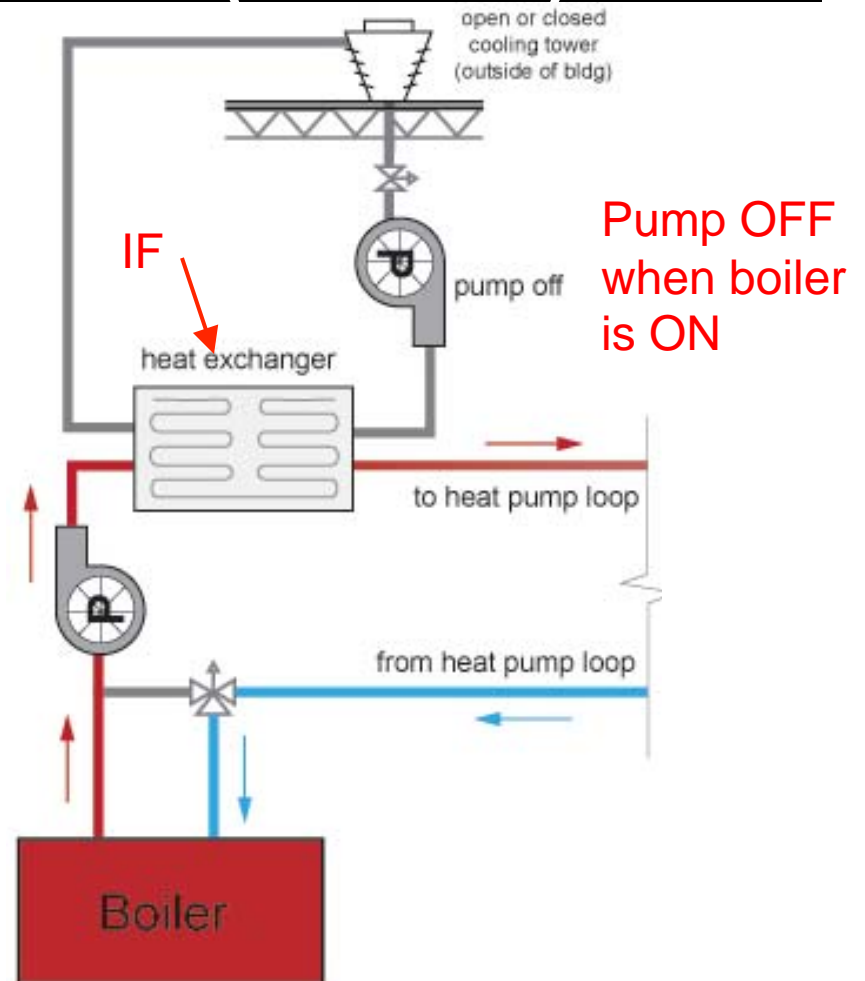

503.4.3.3 Hydronic Water Loop Heat Pump Systems (cont'd)

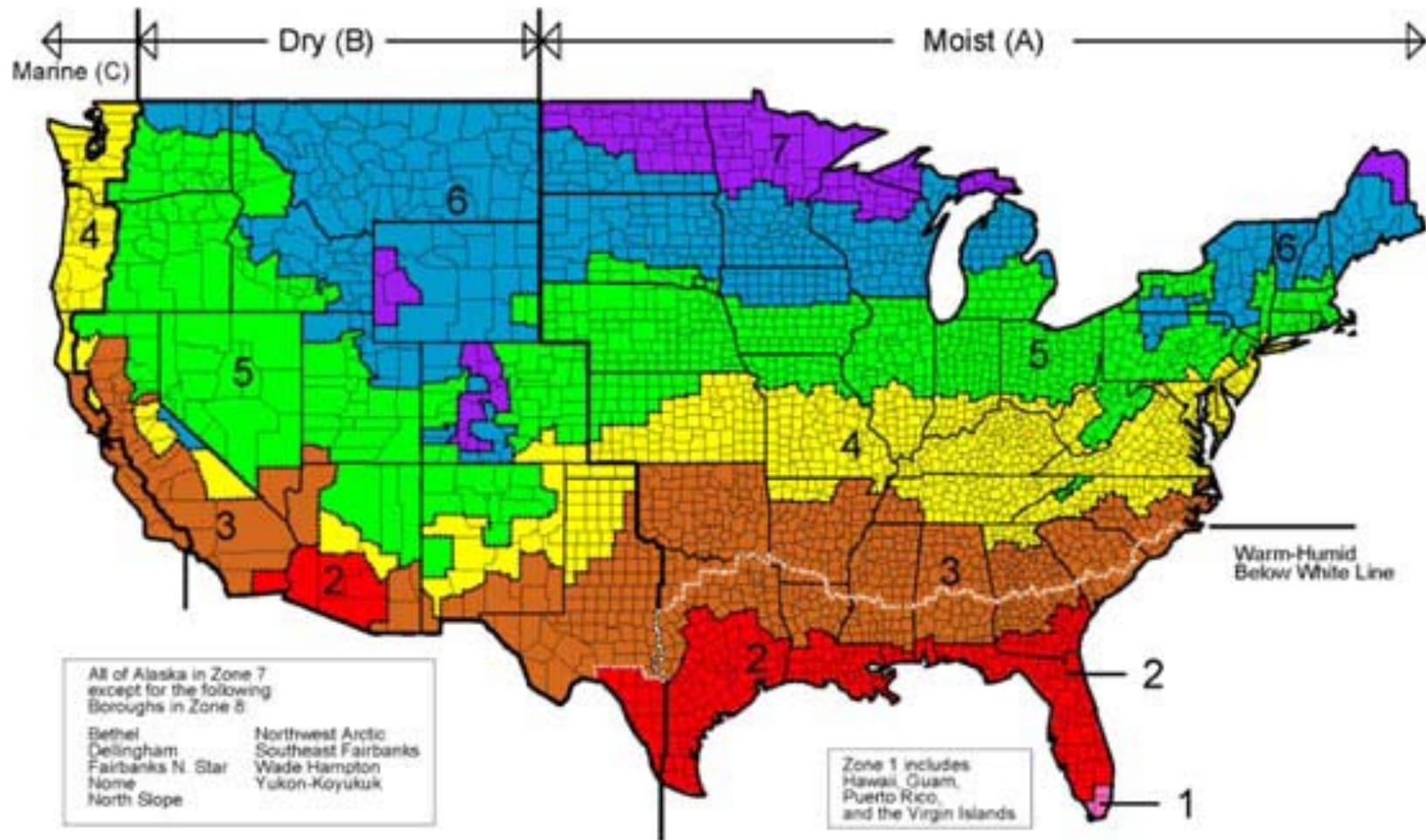

503.4.3.3 Hydronic Water Loop Heat Pump Systems (cont'd)

Heat rejection equipment in Climate Zones 5 - 8

- ✓ Open- or closed-circuit cooling tower used
 - Must have a separate heat exchanger to isolate cooling tower from heat pump loop*
 - Heat loss controlled by shutting down circulation pump on cooling tower loop and providing an automatic valve to stop flow of fluid*
-
-

503.4.3.3 Hydronic Water Loop Heat Pump Systems (cont'd)

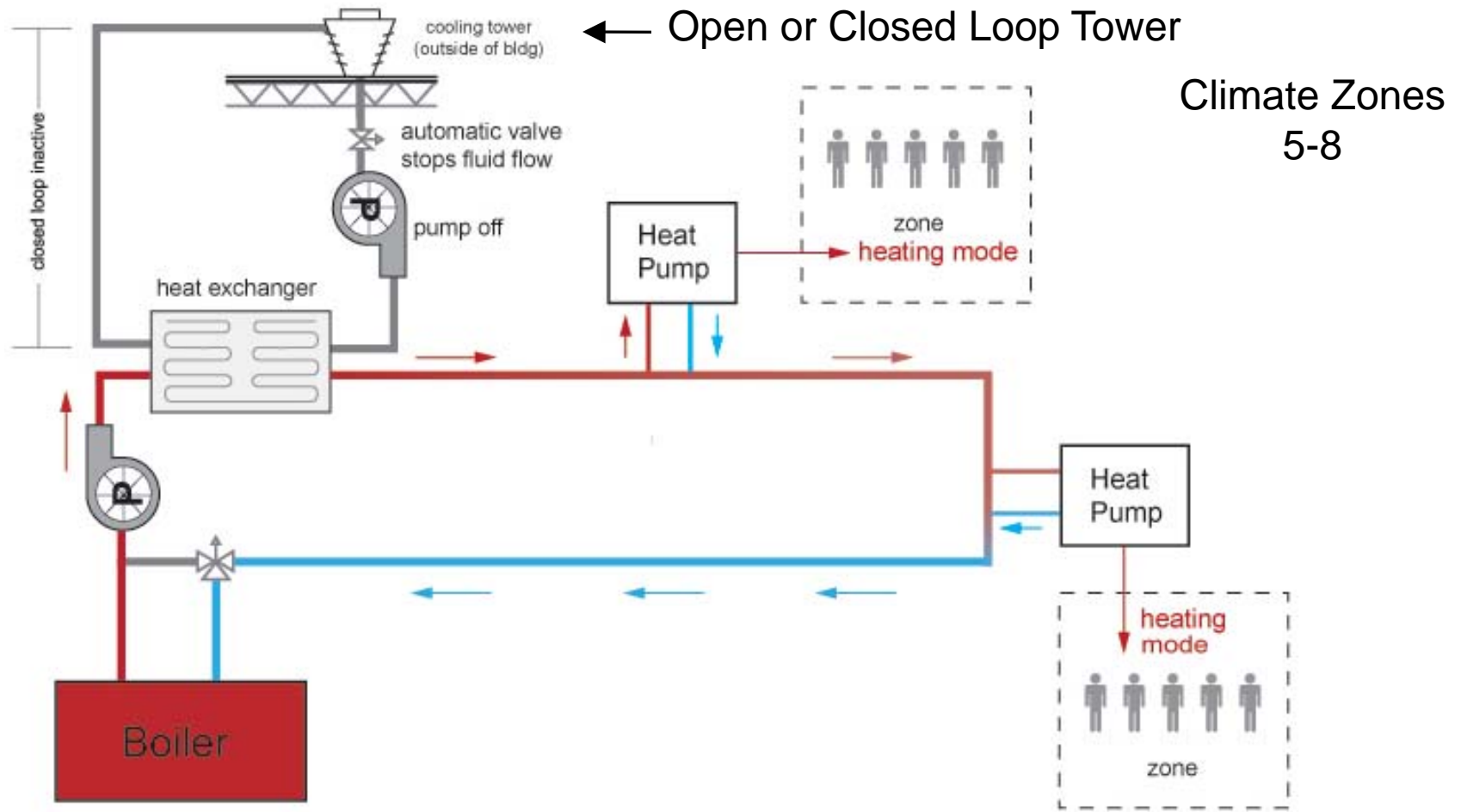

503.4.3.3 Hydronic Water Loop Heat Pump Systems (cont'd)

Two position valve

(503.4.3.3.3)

- ✓ Required on each hydronic heat pump with total pump system power > 10 hp

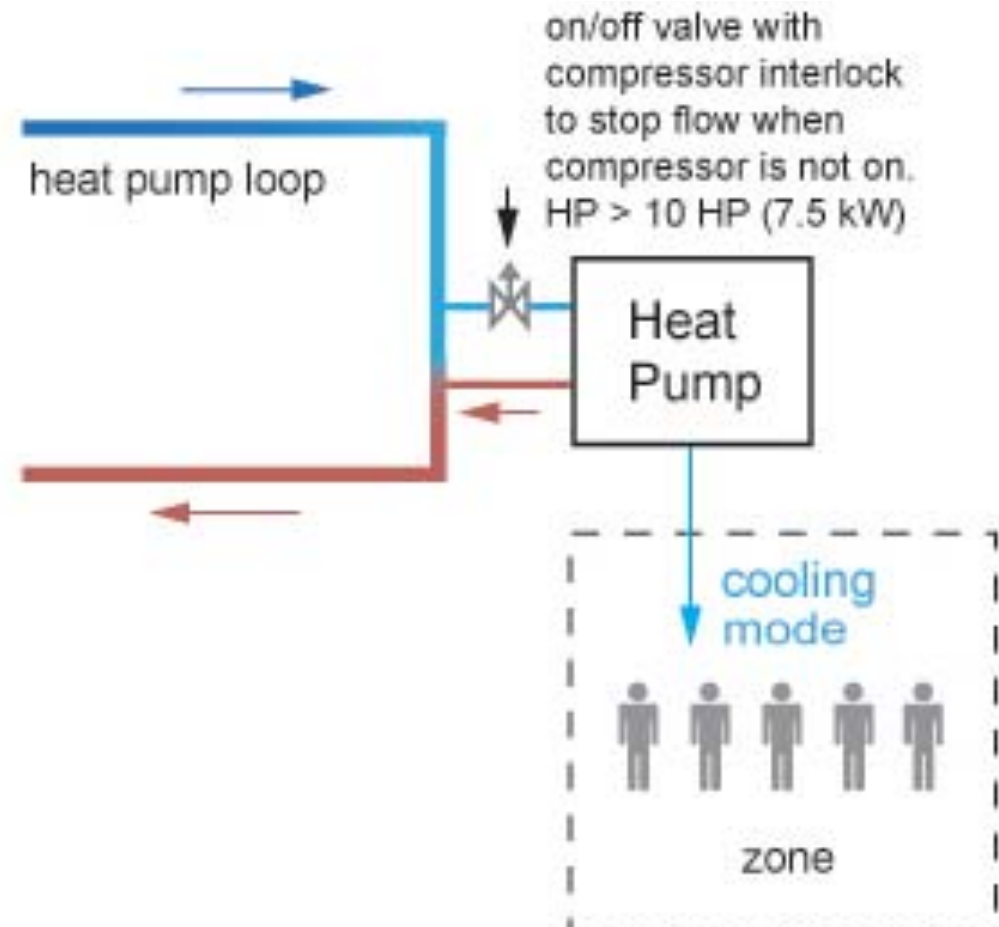

503.4.3.4 Part Load Controls Hydronic Systems

System \geq 300,000 Btu/h

- ✓ Automatic Resets for Supply Water Temperature by 25% of Design Supply-to-Return Temperature Differences

OR

- ✓ Reduce System Pump Flow by 50% of Design Flow Using
 - Multiple Staged Pumps
 - Adjustable Speed Drives
 - Control Valves with Modulate or Step Down Capabilities
-
-

503.4.3.5 Pump Isolation Chilled Water & Boiler Plants

Multiple chiller/boiler water plants

- ✓ Capability to reduce flow automatically when chiller is shut down
- ✓ Chillers piped in series considered one chiller
- ✓ Parallel piped chiller/boiler valved off when not in use



503.4.4 Heat Rejection Equipment Fan Speed Control

Each fan powered by a motor ≥ 7.5 hp to have capability to operate that fan at $2/3$ of full speed or less

AND

Have controls to automatically change the fan speed to control the leaving fluid temperature or condensing temperature/pressure of the heat rejection device

Exception

Factory-installed heat rejection devices within HVAC equipment tested and rated in accordance with Tables 503.2.3(6) and 503.2.3(7)

503.4.5 Multiple Zone System VAV-What is it

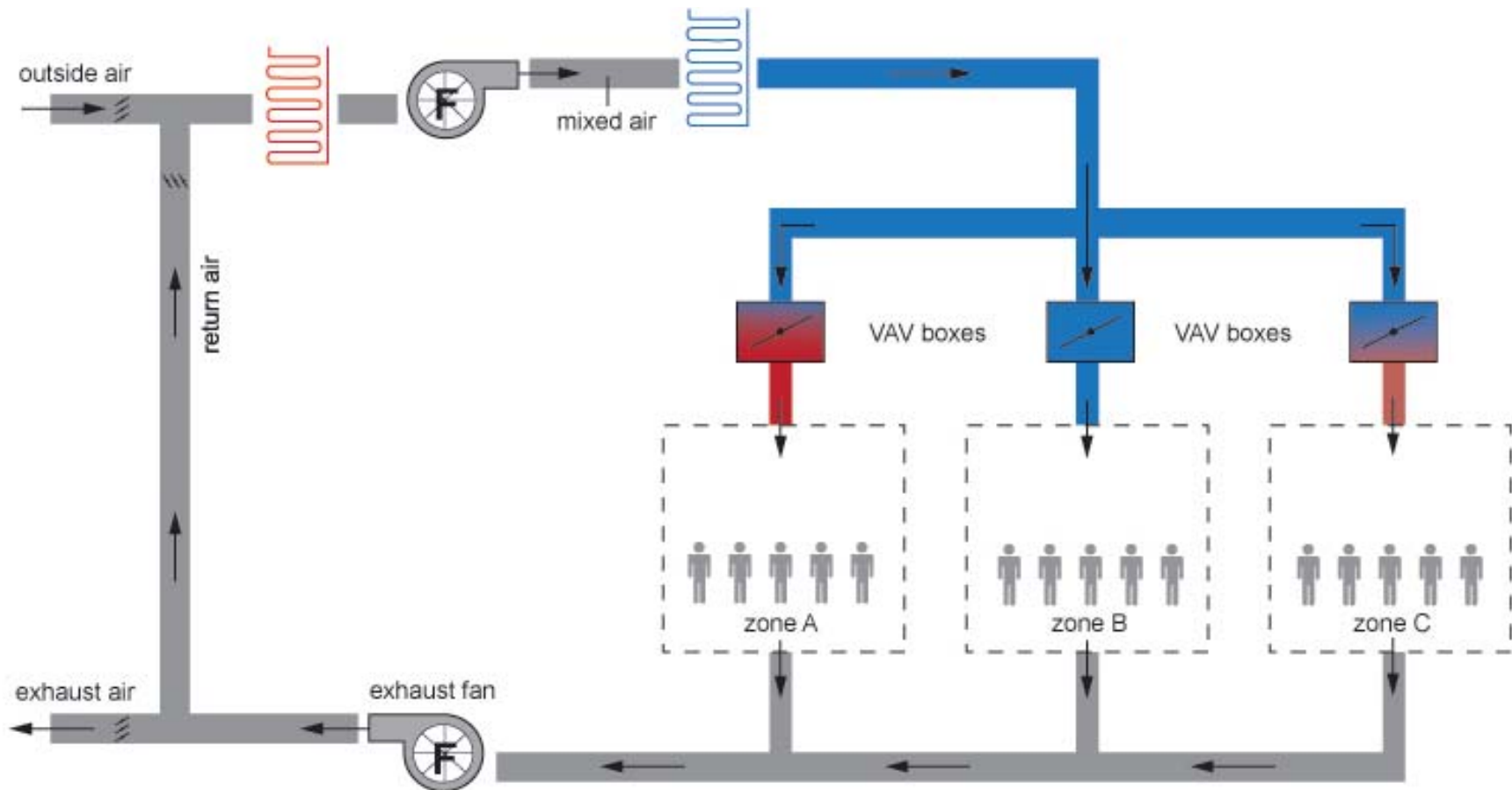

503.4.5 Multiple Zone System Requirements

VAV Systems must be designed and capable of being controlled to reduce the primary air supply to each zone to one of the following before reheat, re-cool, or mixing take place

- ✓ 30% of the maximum supply air to each zone
 - ✓ < 300 cfm where the maximum flow rate is < 10% of total fan system supply airflow rate
 - ✓ Minimum ventilation requirements from Chapter 4 of the IMC
-
-

503.4.5 Multiple Zone System Requirements

- ✓ <30% of the maximum supply air to each zone

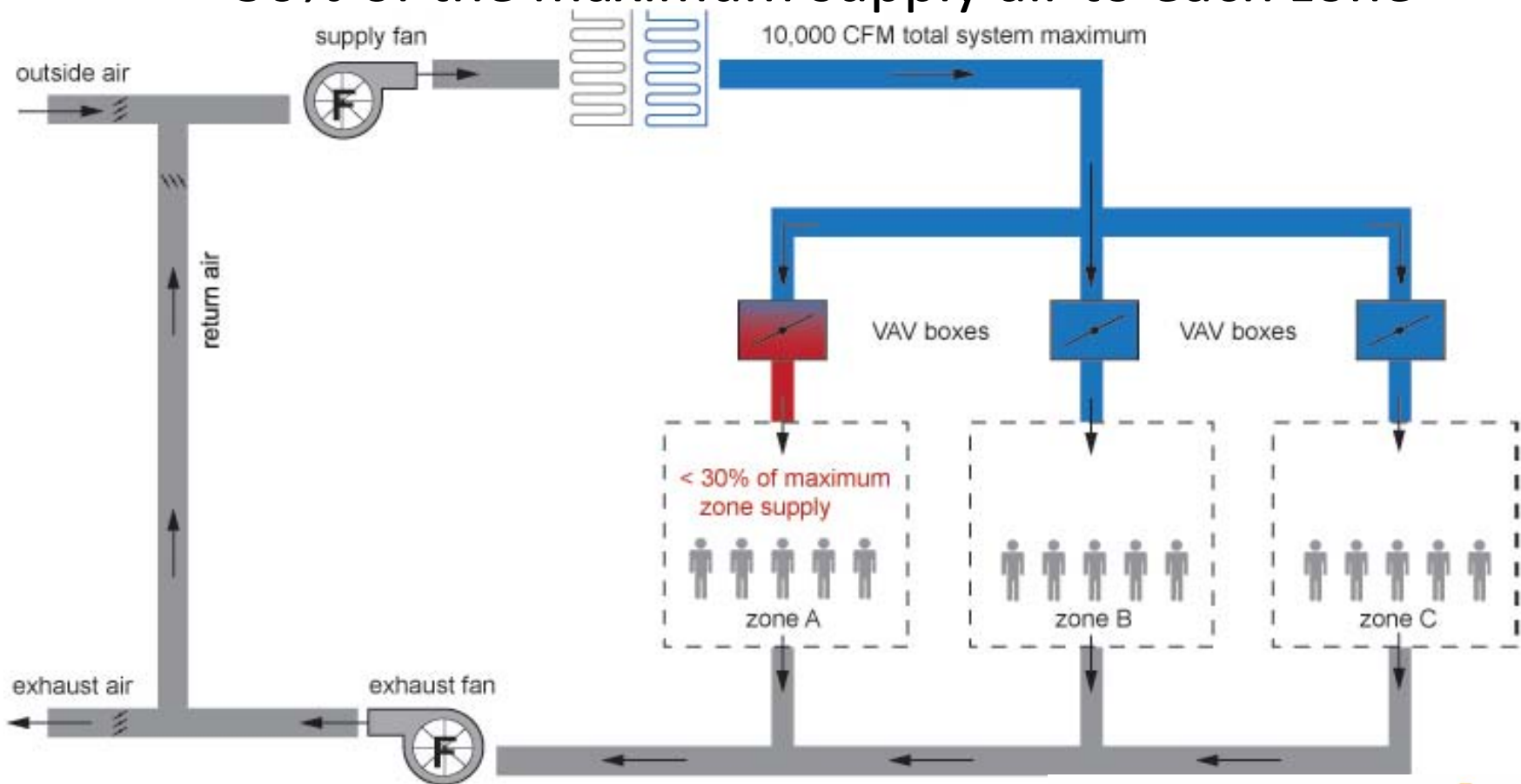

503.4.5 Multiple Zone System Requirements

- ✓ Minimum ventilation requirements from Chapter 4 of the IMC

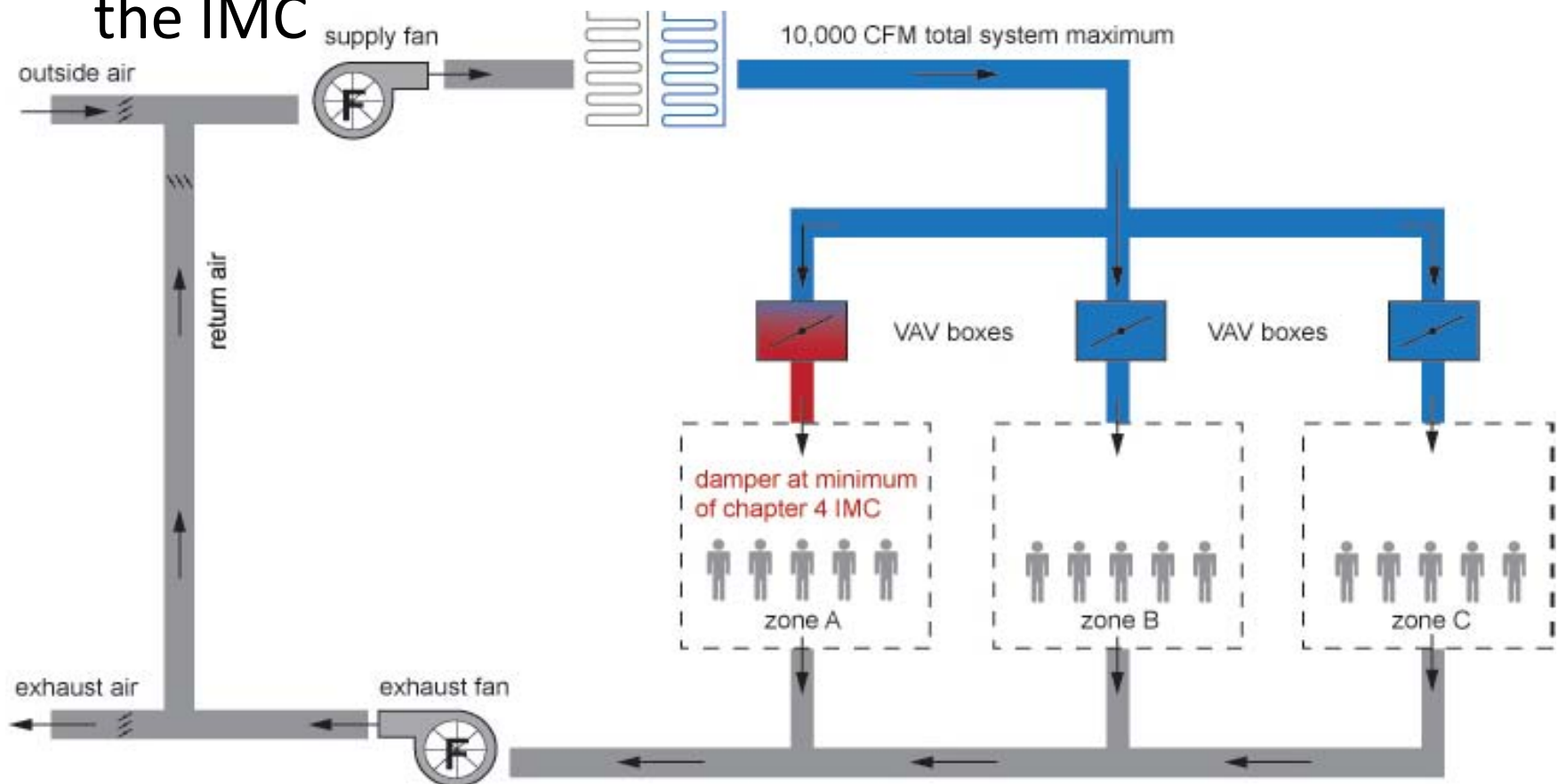

503.4.5 Multiple Zone System Requirements

- ✓ < 300 cfm where the maximum flow rate is < 10% of total fan system supply airflow rate

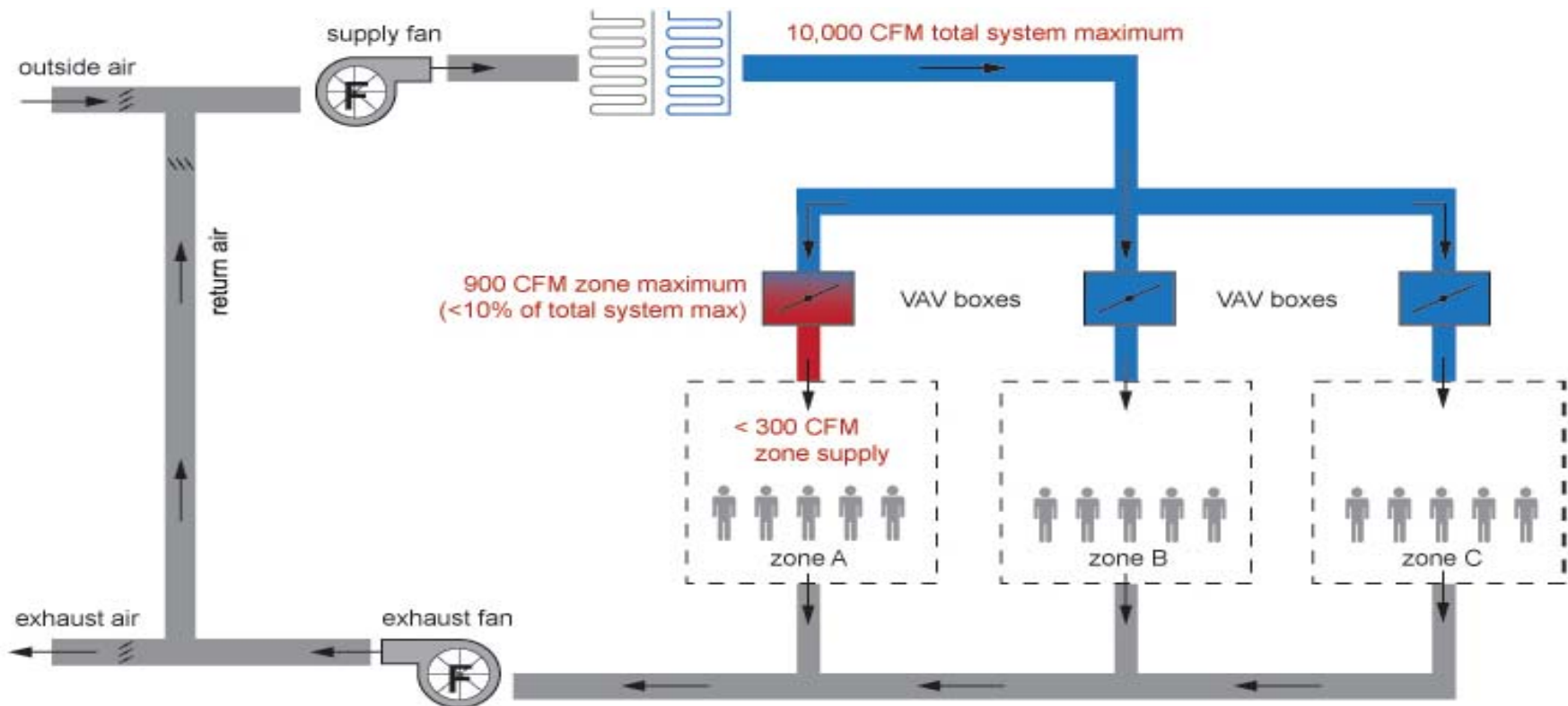

Variable Air Volume System or Zone

Exceptions

Zones with special pressurization or cross-contamination requirements

Where 75% of reheat energy comes from site-recovered or site-solar energy source

Zones with special humidity requirements

Zones with ≤ 300 cfm peak supply and flow rate is $< 10\%$ of total fan system supply airflow rate

Zones where reheated, re-cooled or mixed air volume $<$ minimum ventilation requirements (Chapter 4 of IMC)

Systems with controls capable of preventing reheating, re-cooling, mixing or simultaneous supply of air previously heated or cooled

503.4.5.1 Single Duct VAV Systems, Terminal Devices

Single duct VAV systems to use terminal devices capable of reducing the supply of primary supply air before reheating or re-cooling takes place

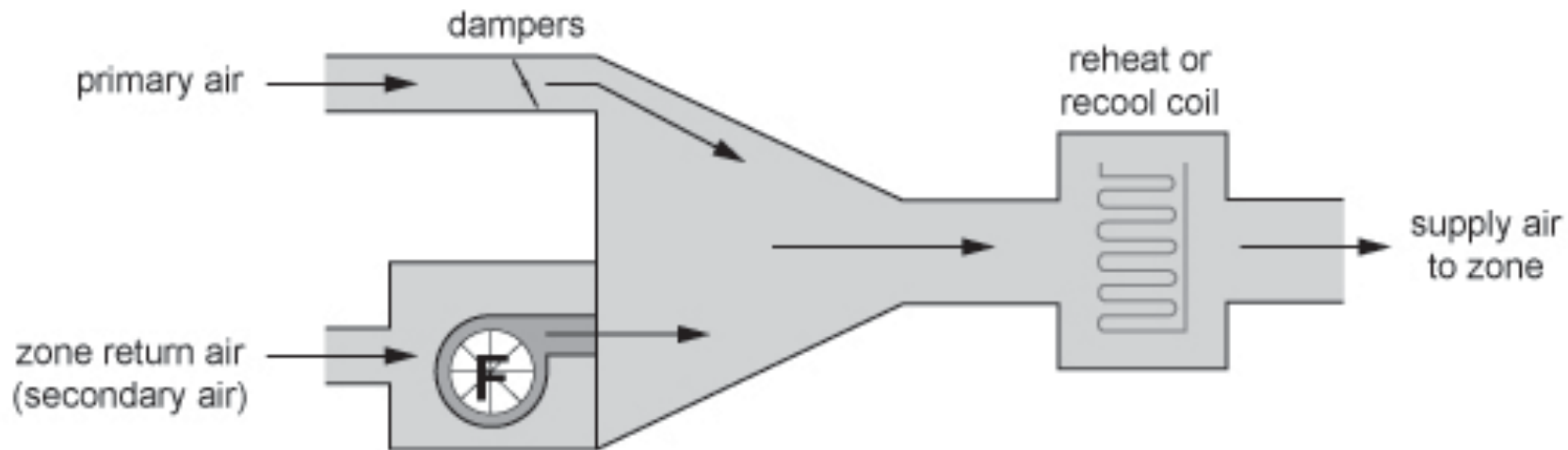

503.4.5.2 Dual Duct and Mixing VAV Systems, Terminal Devices

Systems with one warm air duct and one cool air duct to use terminal devices capable of reducing flow from one duct to a minimum before mixing of air from the other duct takes place

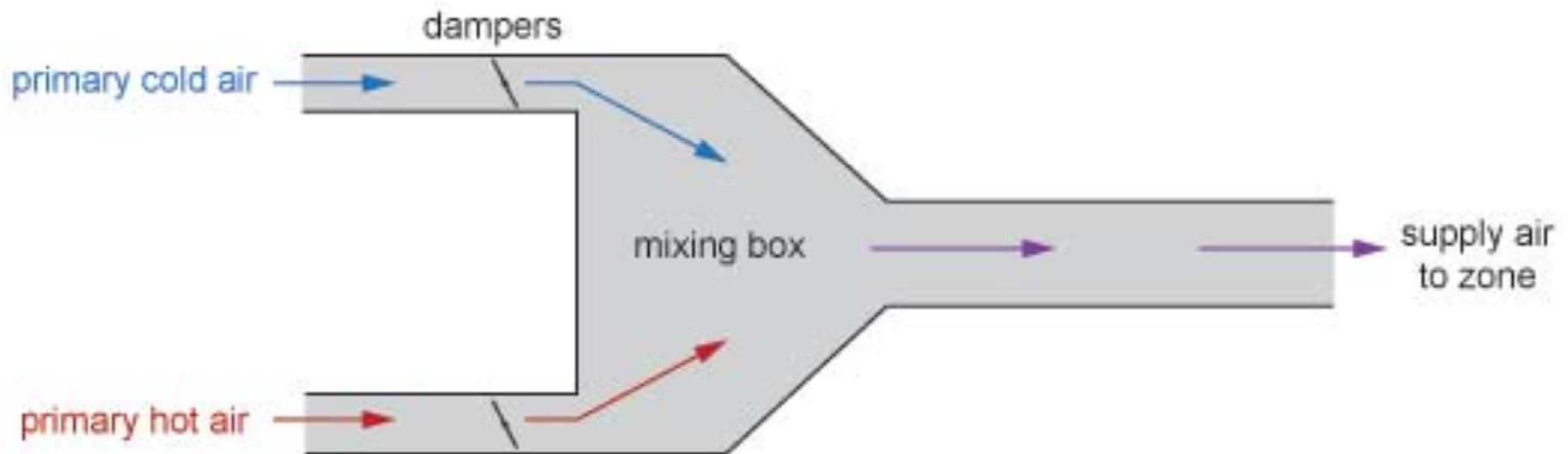

503.4.5.3 Single Fan Dual Duct and Mixing VAV Systems, Economizers

Individual dual duct or mixing reheating and cooling systems with a single fan and with total capacities

- >90,000 Btu/h shall not have economizers
 - *This is because outside air may add humidity that the heat side is trying de-humidify the air. This would be a less like scenario in locations such as the dry west.*
-
-

503.4.5.4 Supply-Air Temperature Reset Controls

Multiple zone HVAC systems to have controls to automatically reset supply-air temperature in response to building loads or outdoor air temperature

Design Supply Air = 50 F

Design Room Air = 70 F

25% (70 F - 50 F) =
5 F *Minimum* Reset

Controls to be capable of resetting supply air temperature at least 25% of difference between design supply-air temperature and design room air temperature

This helps to eliminate simultaneous heating and cooling

503.4.5.4 Supply-Air Temperature Reset Controls- Design Condition

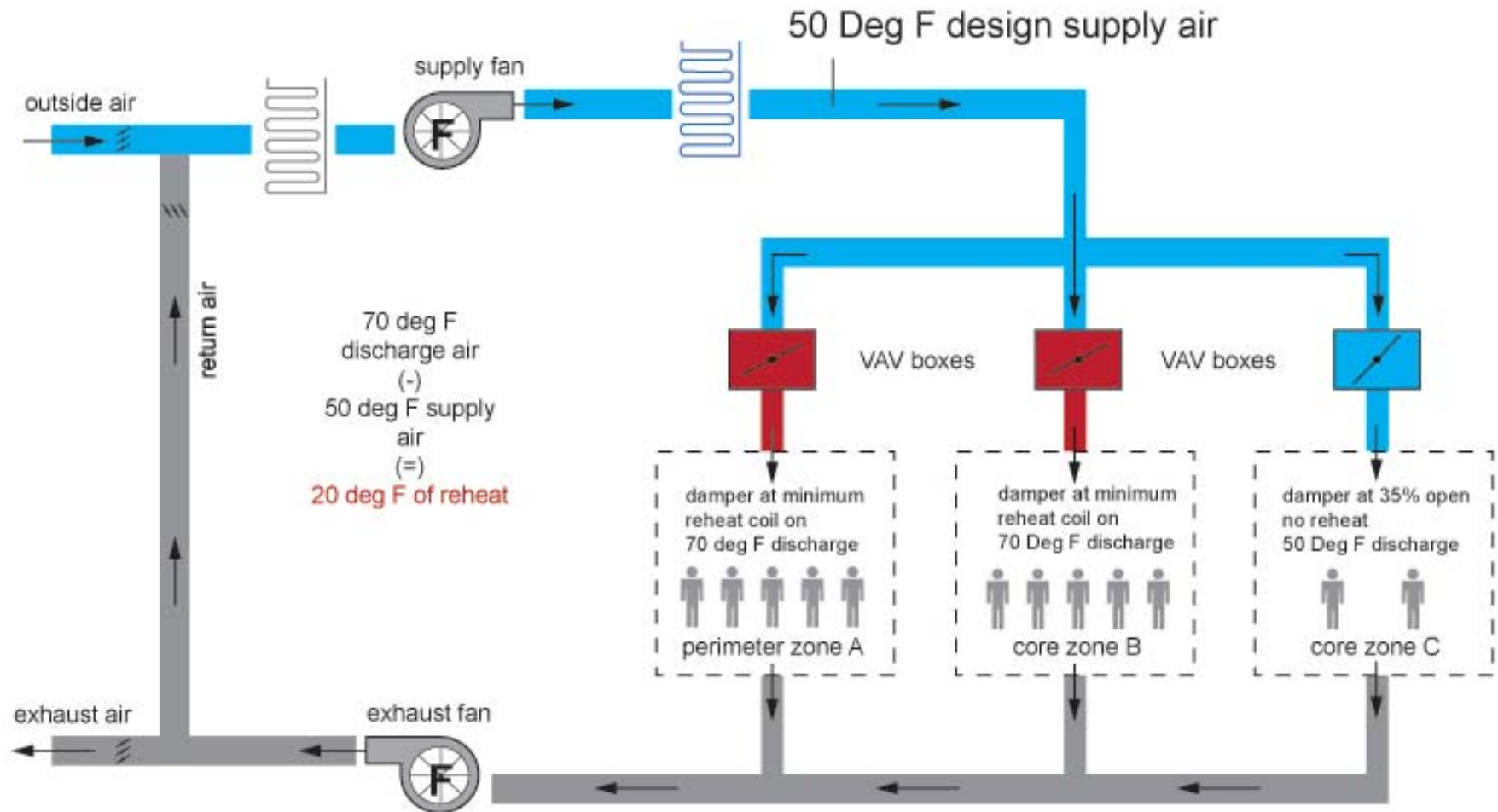

503.4.5.4 Supply-Air Temperature Reset Controls- After Reset

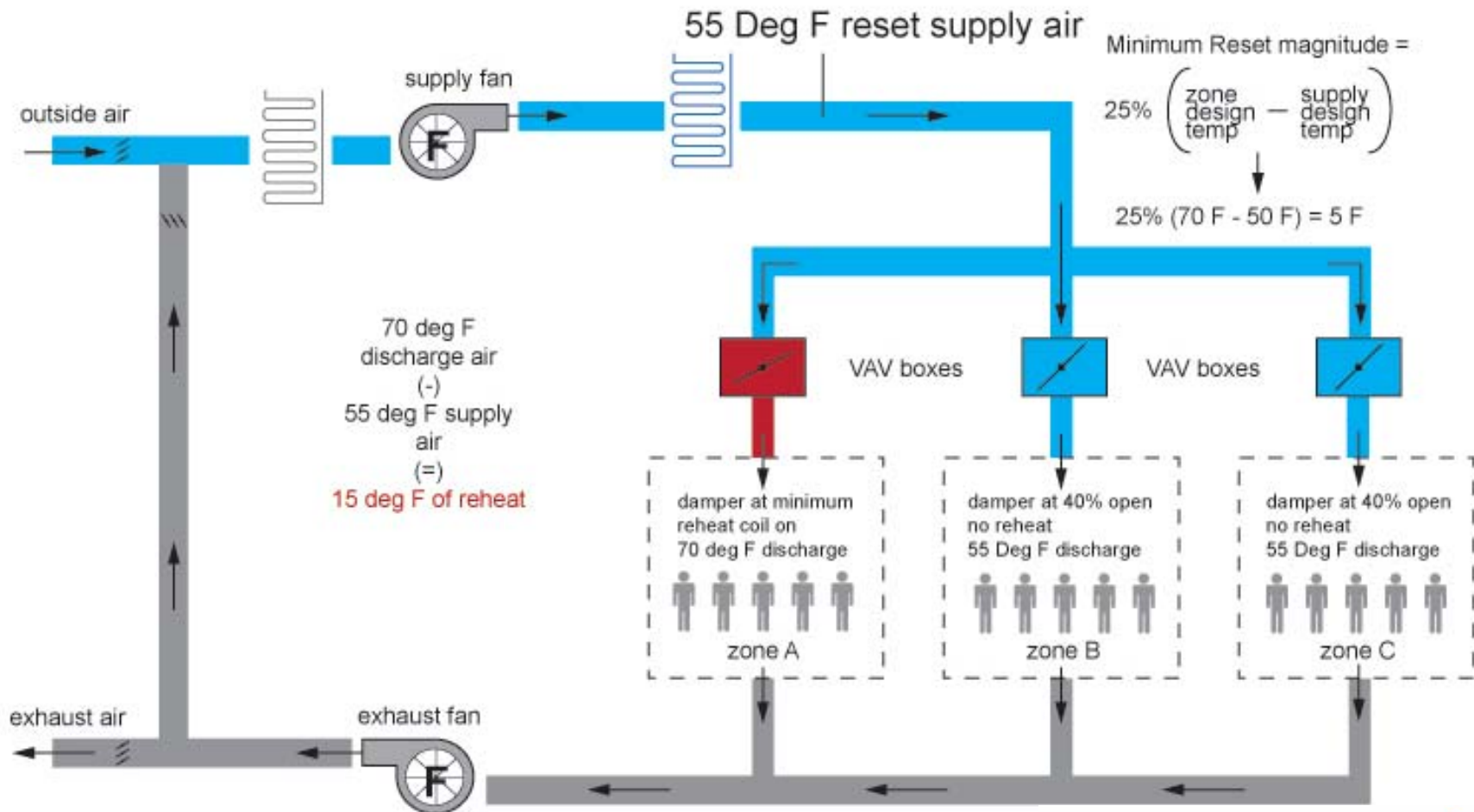

Supply-Air Temperature Reset Controls *Exceptions*

Systems that prevent reheating, re-cooling or mixing of heated and cooled supply air

75% of energy for reheating is from site-recovered or site solar energy sources

Zones with peak supply air quantities of ≤ 300 cfm

503.4.6 Heat Recovery for Service Hot Water Heating

Most effective where water heater loads are large and well distributed throughout the day

Typical applications: hotels, dorms, prisons, hospitals

Condenser heat recovery required for heating/reheating of SWH provided:

- ✓ Facility operates 24 hours/day
 - ✓ Total installed heat capacity of water-cooled systems >6,000,000 Btu/hr of heat rejection
 - ✓ Design SWH load >1,000,000 Btu/h
-
-

503.4.6 Heat Recovery for Service Hot Water Heating

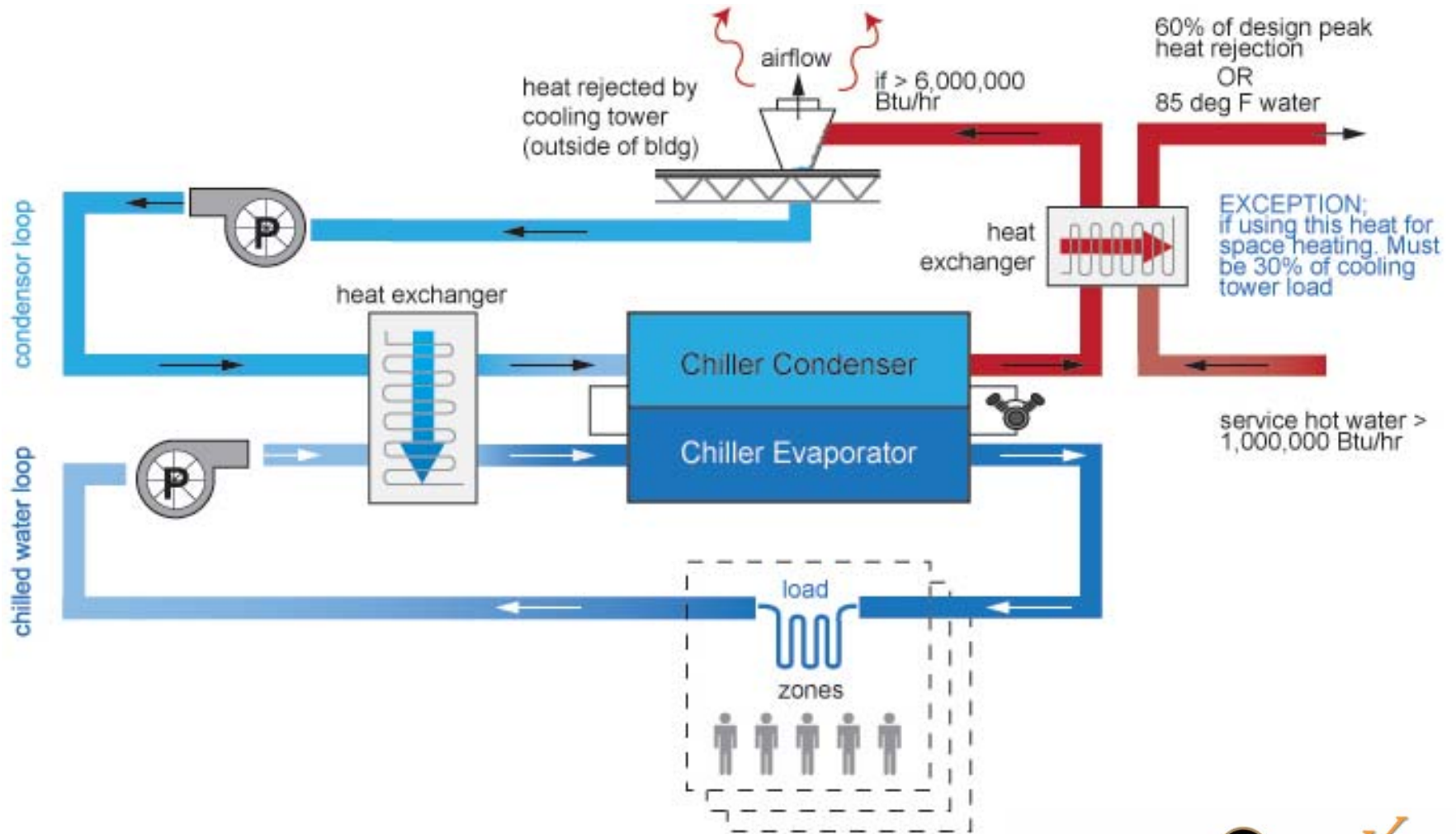

503.4.6 Heat Recovery for Service Hot Water Heating

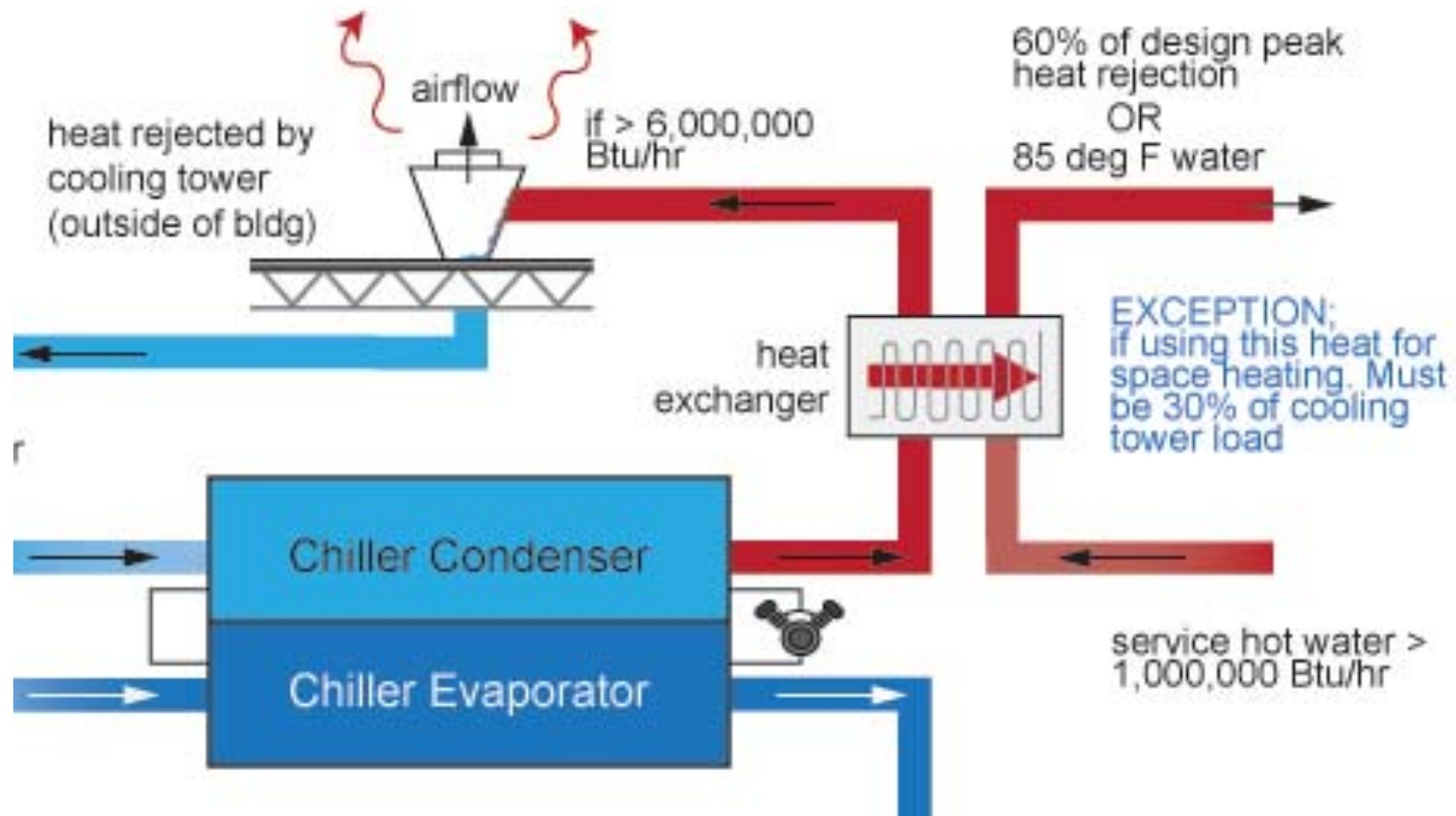

503.4.6 Heat Recovery for Service Hot Water Heating (cont'd)

Capacity to provide the smaller of
60% of peak heat rejection load at design conditions

OR

Preheating to raise peak to 85°F

Exceptions

- ✓ Facilities that employ condenser heat recovery for space heating or reheat purposes with a heat recover design exceeding 30% of the peak water-cooled condenser load at design conditions.
 - ✓ Facilities that provide 60% of their service water heating from site solar or site recovered energy or from other sources.
-
-

503.4.7 Hot Gas Bypass

Cooling systems can't use unless system designed with

- ✓ Multiple steps of unloading OR
- ✓ Continuous capacity modulation

Capacity limited per Table 503.4.7

Exception

- ✓ **Unitary packaged systems with cooling capacities < 90,000 Btu/h (7.5 tons)**

Rated Capacity	Maximum Hot Gas Bypass Capacity (% of total capacity)
≤ 240,000 Btu/h	50%
> 240,000 Btu/h	25%

503.4.7 Hot Gas Bypass

What is it?

Dumps hot gas from compressor outlet to evaporator inlet

-Inefficient because no useful work is done by bypassed gas

For comfort cooling it should not be needed, good design along with the requirements of this section will preclude its use.

Why use it?

Possible Application: Large chillers run at very low loads will start and stop often (very bad for equipment) so HGBP is used to place a false load on the evaporator.

Possible Application: Very tight temperature control is needed on the evaporator- high tech process applications

503.4.7 Hot Gas Bypass

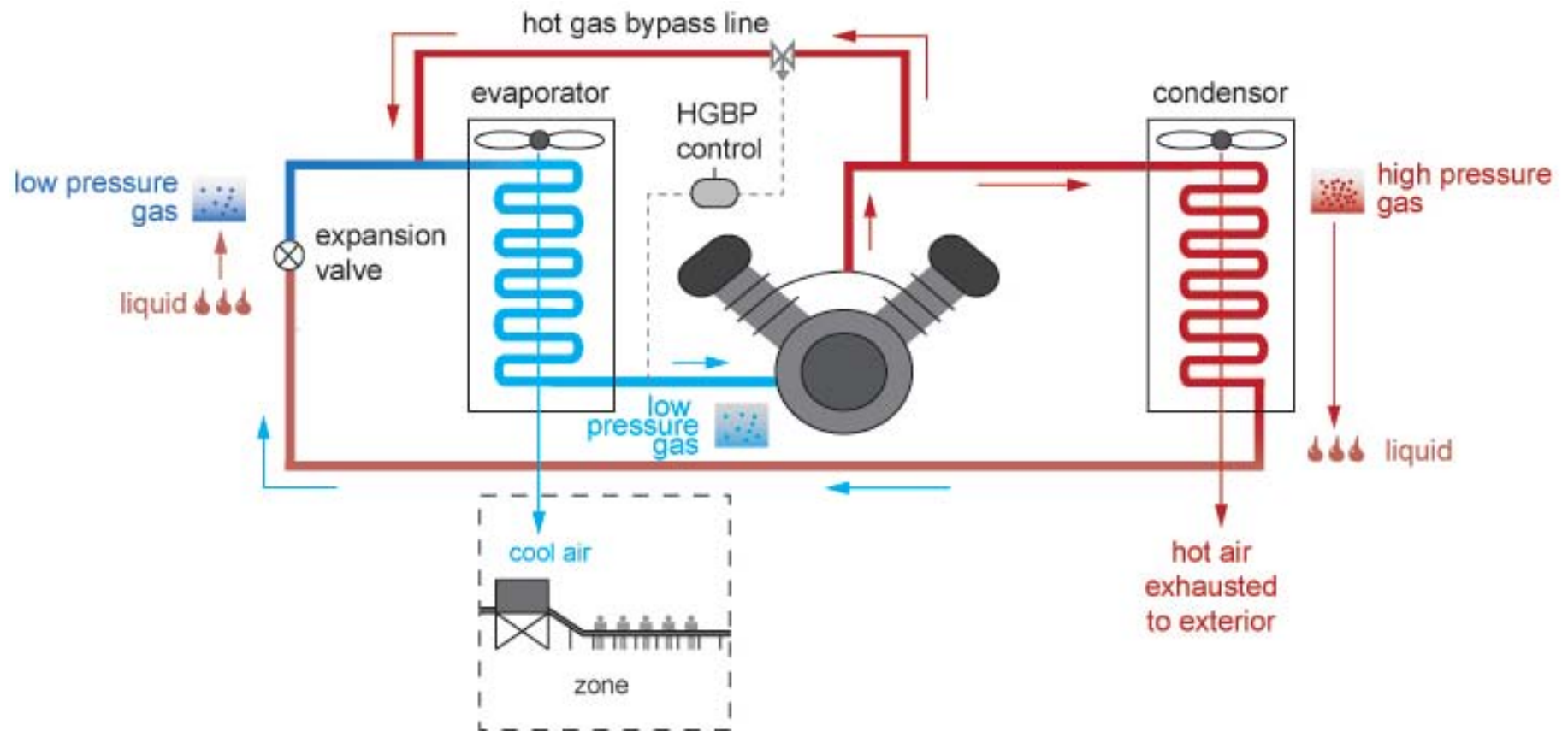

503.4.7 Hot Gas Bypass- By Code

HGBP only used when systems have multiple steps of unloading (multiple compressors) or continuous capacity modulation (VFDs)

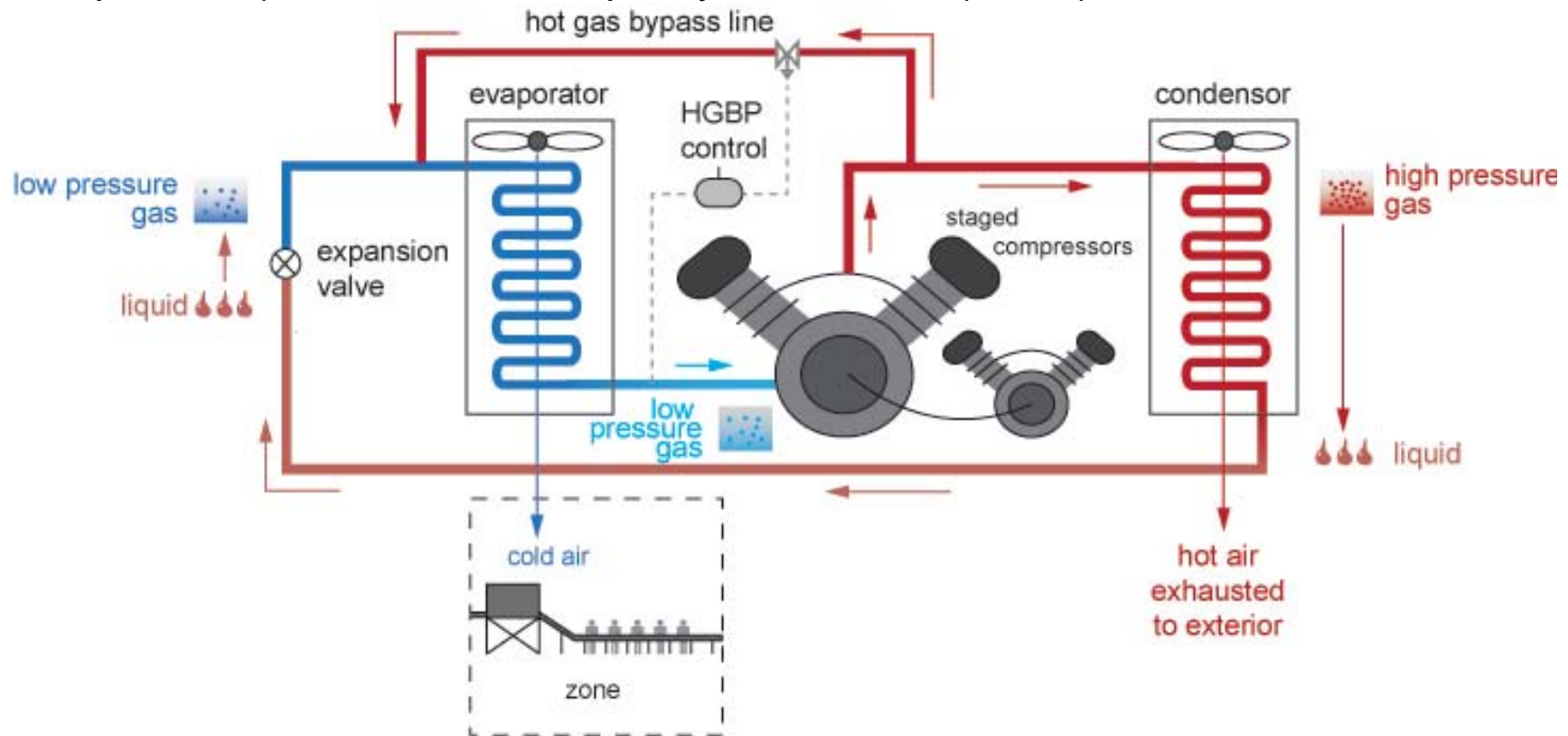

Questions & Answers



Guide Sponsors

